

THERMO
AIR

Mounting instruction **EN**

Montageanleitung **DE**

Notice de montage **FR**

Montagehandleiding **NL**

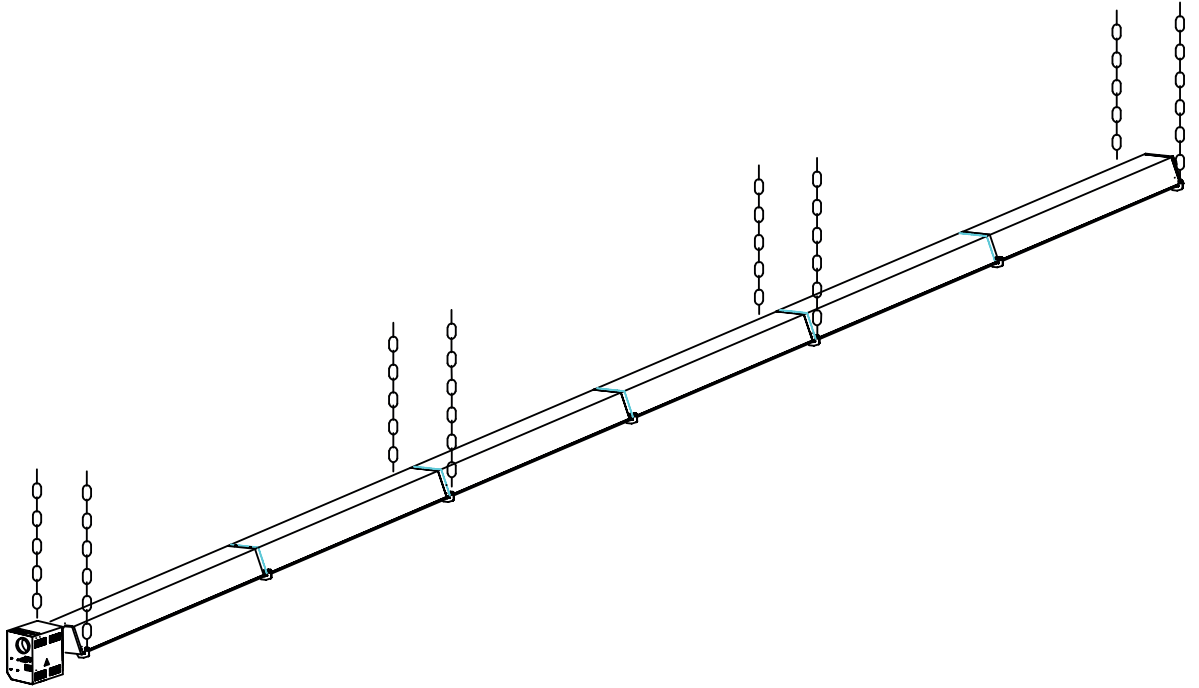

BH
0666557

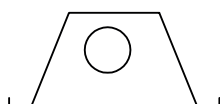







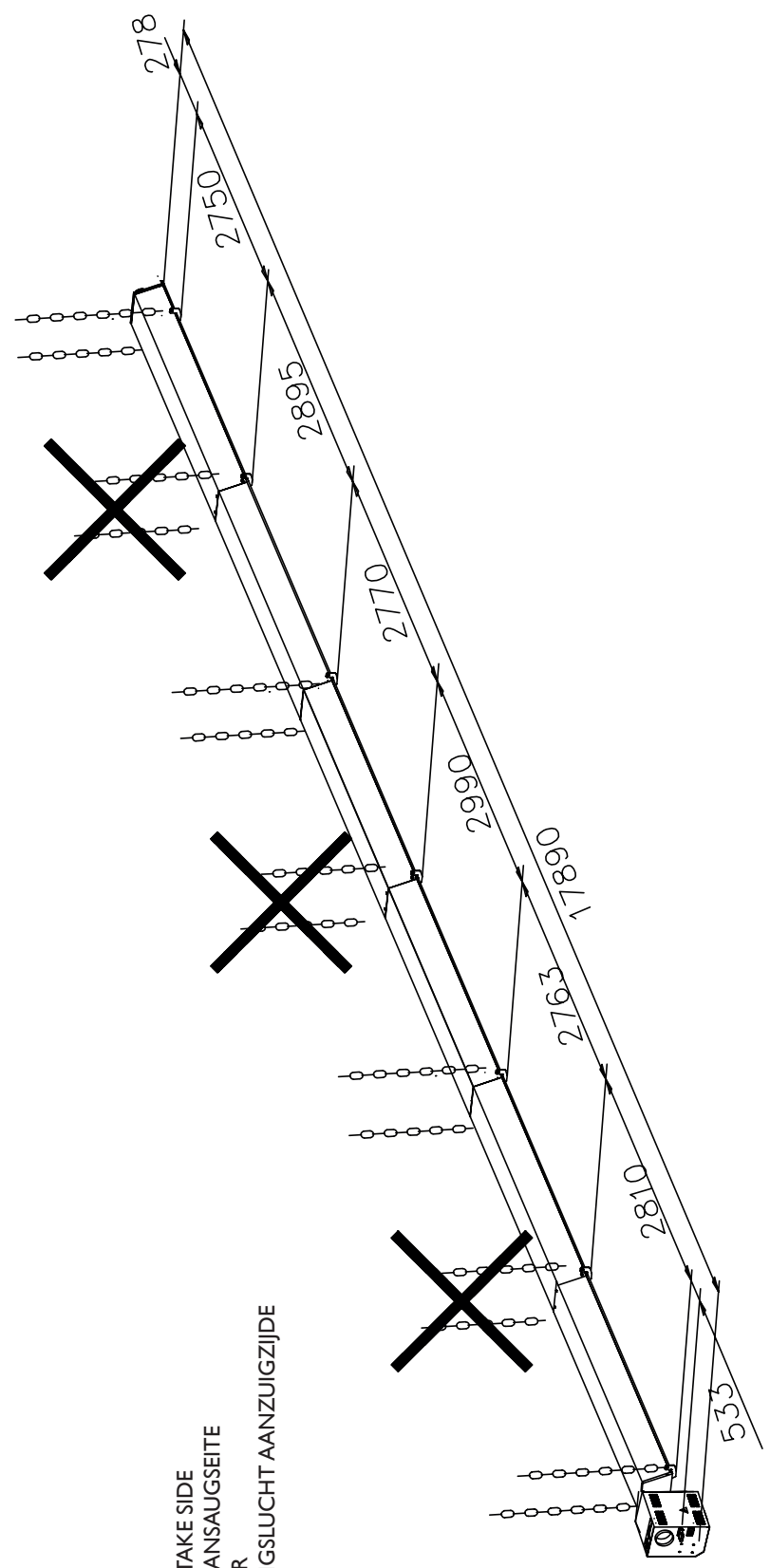

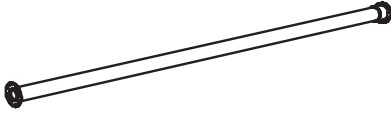
50-18

EXHAUST AIR SIDE
ABGAS AUSTRITT
ÉVACUATION DE GAZ FUMIGÈNE
ROOKGAS AFVOERZIJDE

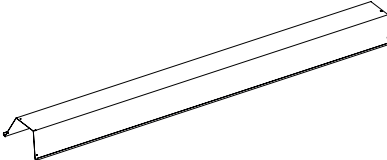
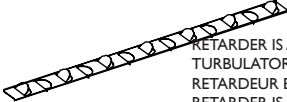
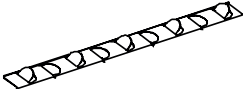
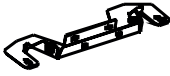
FRESH AIR INTAKE SIDE
FRISCH LUFT ANSAUGSEITE
ARRIVÉE D'AIR
VERBRANDINGSLUCHT AANZUIGZIJDE

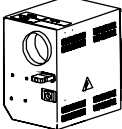

RADIANT TUBE STRAHLUNGSRÖHR TUBE RAYONNANT STRALINGBUIS	L=2880	1x		30 61 373
RADIANT TUBE STRAHLUNGSRÖHR TUBE RAYONNANT STRALINGBUIS	L=2880	1x		30 61 372
RADIANT TUBE STRAHLUNGSRÖHR TUBE RAYONNANT STRALINGBUIS	L=2880	3x		30 61 371
RADIANT TUBE STRAHLUNGSRÖHR TUBE RAYONNANT STRALINGBUIS	L=2880	1x		30 61 370
REFLECTOR PANEL STRAHLUNGSKAPPE REFLECTEUR STRALINGKAP	L=2883	6x		1455140
RETARDER TURBULATOR RETARDEUR RETARDER	L=1050	1x	 RETARDER IS ALREADY MOUNTED IN TUBE TURBULATOR IST SCHON IM ROHR MONTIERT RETARDEUR EST MONTEZ DANS LA TUBE RETARDER IS AL IN DE BUIS GEPLAATST	1111193
RETARDER TURBULATOR RETARDEUR RETARDER	L=850	1x		1111191
SUSPENSION BRACKET MONTAGEBÜGEL ETRIER DE SUSPENSION OPHANG BEUGEL		7x		13 06 400
END PLATE ENDKAPPE PLAQUES D'EXTRÉMITÉ STRALING EINDKAP		2x		30 87 333
BURNER BRENNER BRÛLEUR BRANDER KAMER		1x		
SLEEVE WITH ADJUSTABLE SCREW CLIP MUFFE MIT SCHLAUCHSCHELLE MANCHON AVEC PINCE A VIS REGABLE AANSLUITMOF MET SLANGENKLEM		1x		3019033

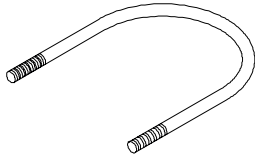

7x

08 14 102

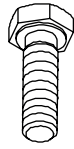

M8x25 27x

08 02 286

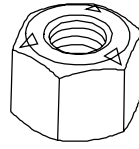

M8 41x

08 76 040



M6x16 6x

08 31 031



6x

08 18 016



M8 14x

08 66 541



4x

04 18 682

19 99 239

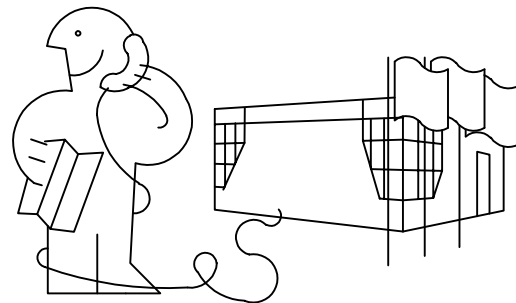
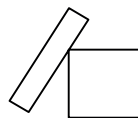
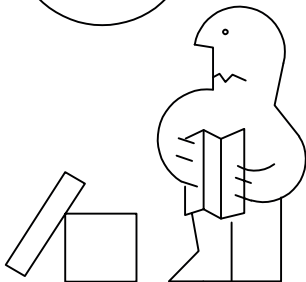

I.1

BURNER SIDE
BRENNERSEITE
COTÉ DE BRÛLEUR
BRANDERZIJDE

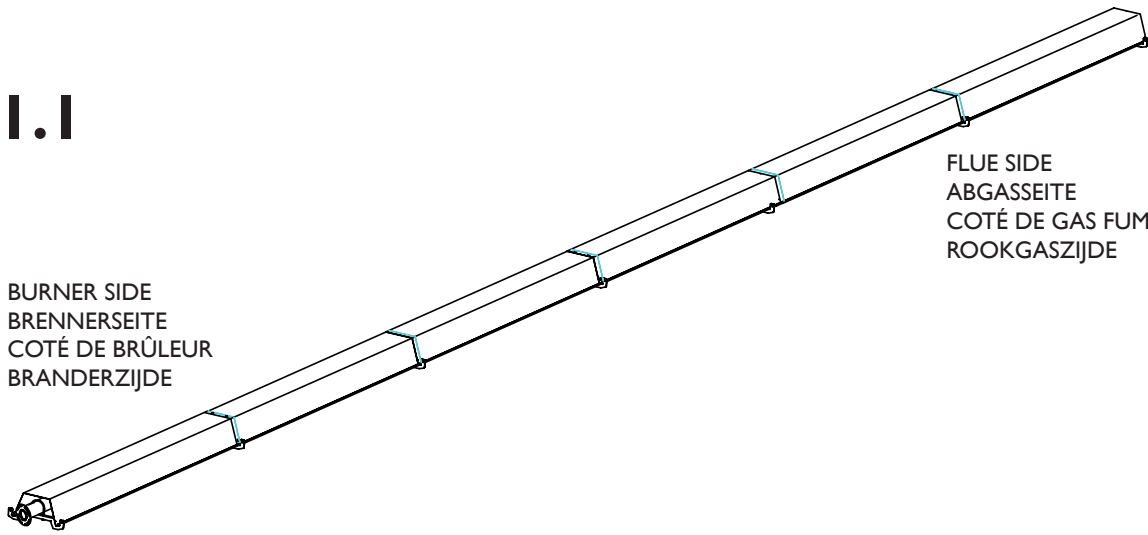

FLUE SIDE
ABGASSEITE
COTÉ DE GAS FUMÉ
ROOKGASZIJDE

I.2

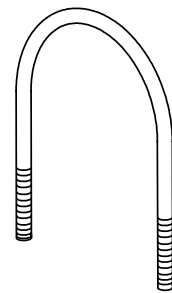
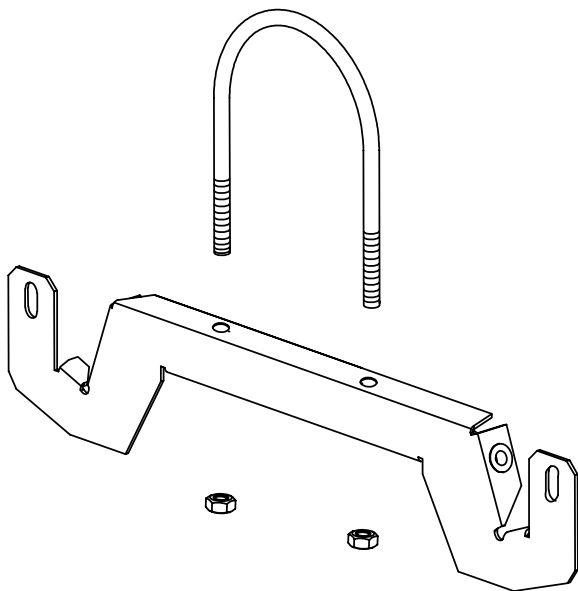

7x



14x



M8 14x

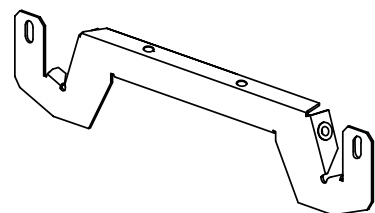

7x

I.3.1

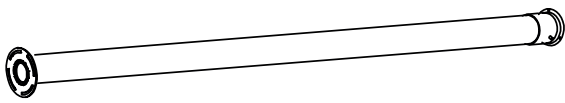
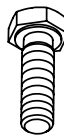
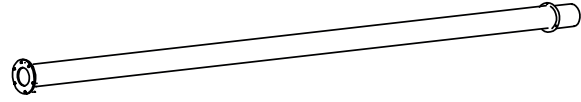
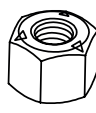
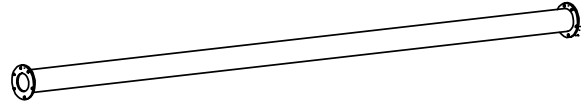
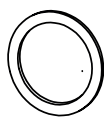
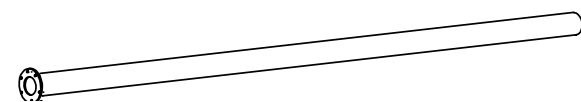
- L=2880 1x   M8x20 27x
- L=2880 1x   M8 27x
- L=2880 3x   4x
- L=2880 1x 

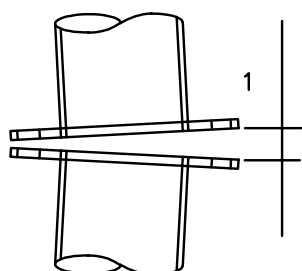

BOLT UP THE WIDEST GAP FIRST
 DIE BREITESTE ÖFFNUNG ZUERST VERSCHRAUBEN
 BOULONNER LE PLUS LARGE PREMIER
 DE BOUT DIE BIJ DE GROOTSTE FLENSOPENING ZIT EERST

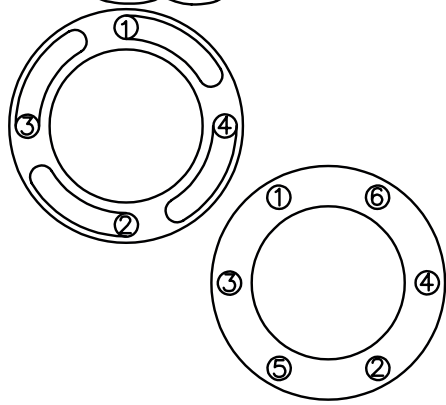

STEP 1: 30%, STEP 2: 60%, STEP 3: 100%, FINAL PULL: 100%
 SCHRITT 1: 30%, SCHRITT 2: 60%, SCHRITT 3: 100%, NACHZIEHEN: 100%
 ÉTAPPE 1: 30%, ÉTAPPE 2: 60%, ÉTAPPE 3: 100%, TIRAGE FINAL: 100%
 STAP 1: 30%, STAP 2: 60%, STAP 3: 100%, AFCIRKELEN: 100%

I.3.2

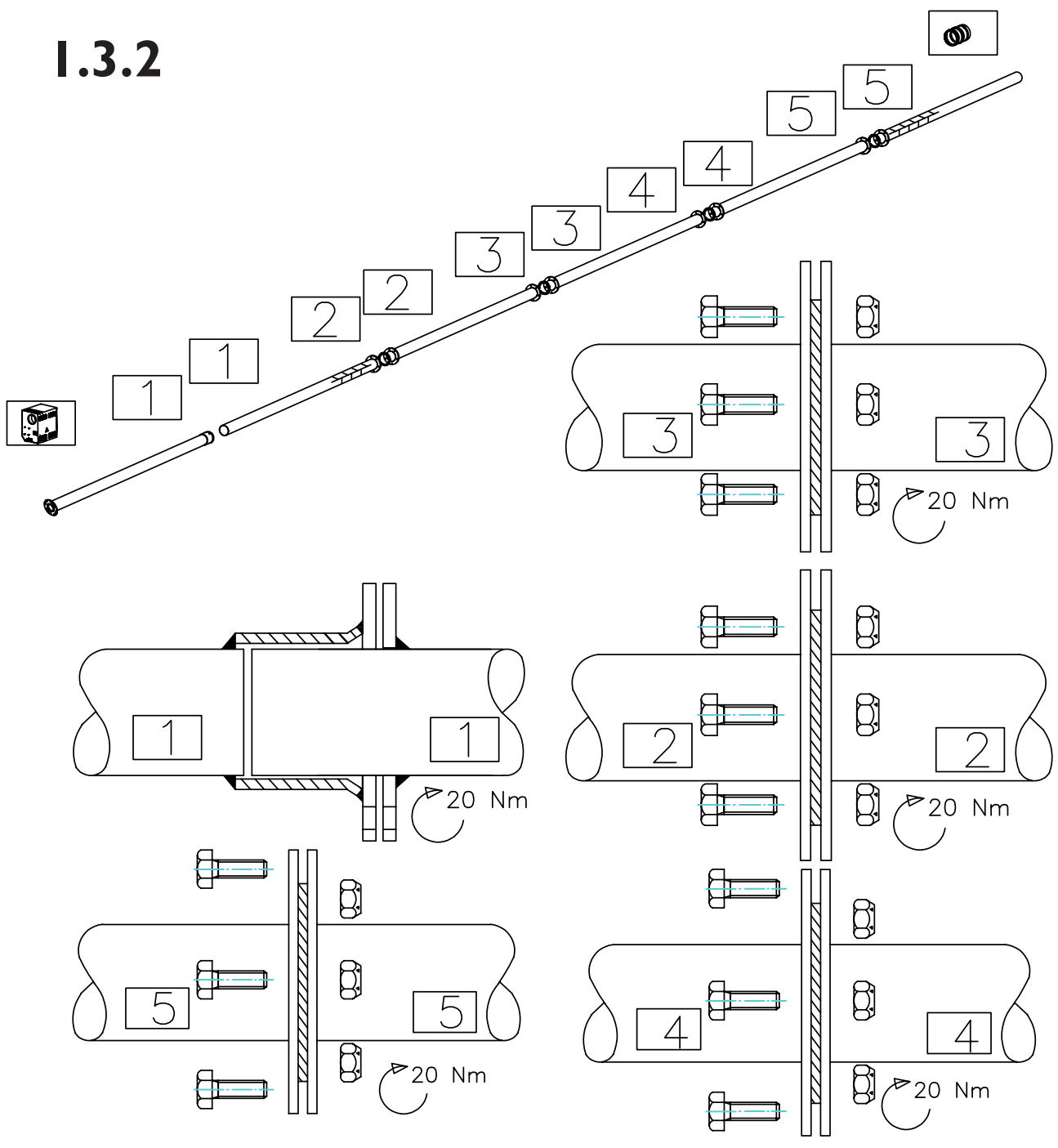

1.4

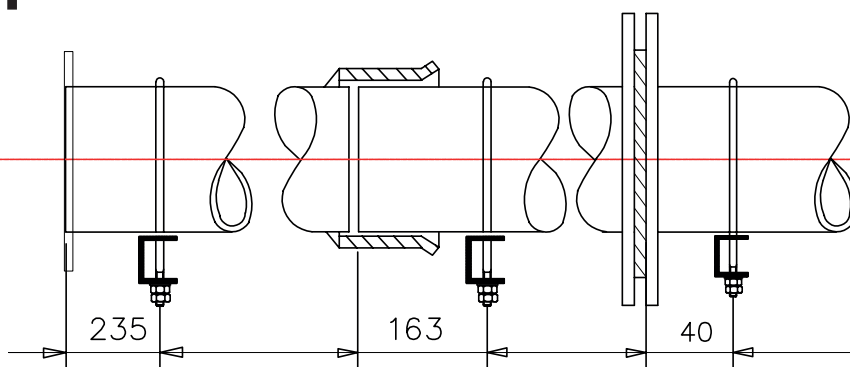

1.1 ... 1.4

BURNER SIDE
BRENNERSEITE
COTÉ DE BRÛLEUR
BRANDERZIJDE

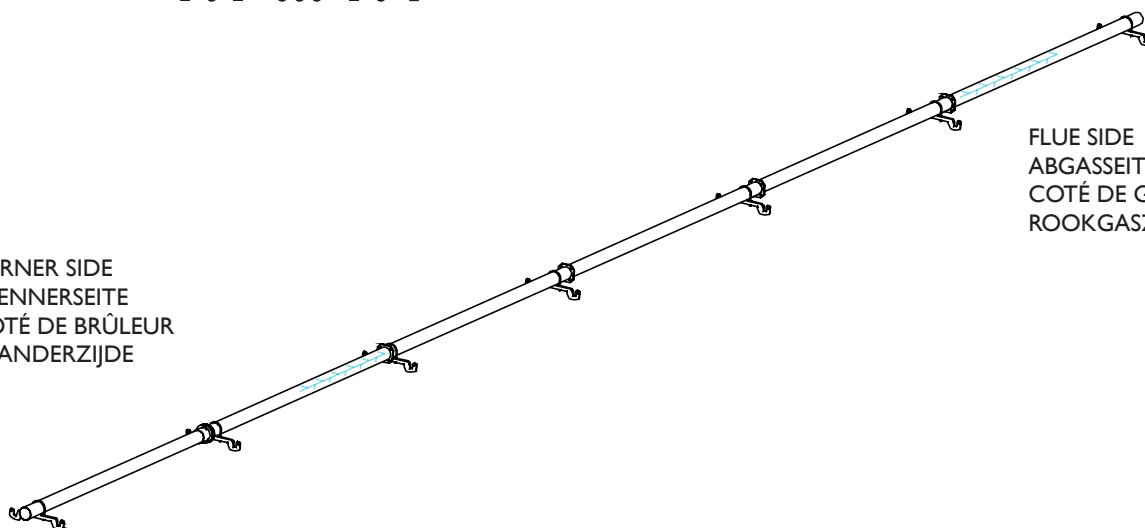

FLUE SIDE
ABGASSEITE
COTÉ DE GAS FUMÉ
ROOKGASZIJDE

2.1

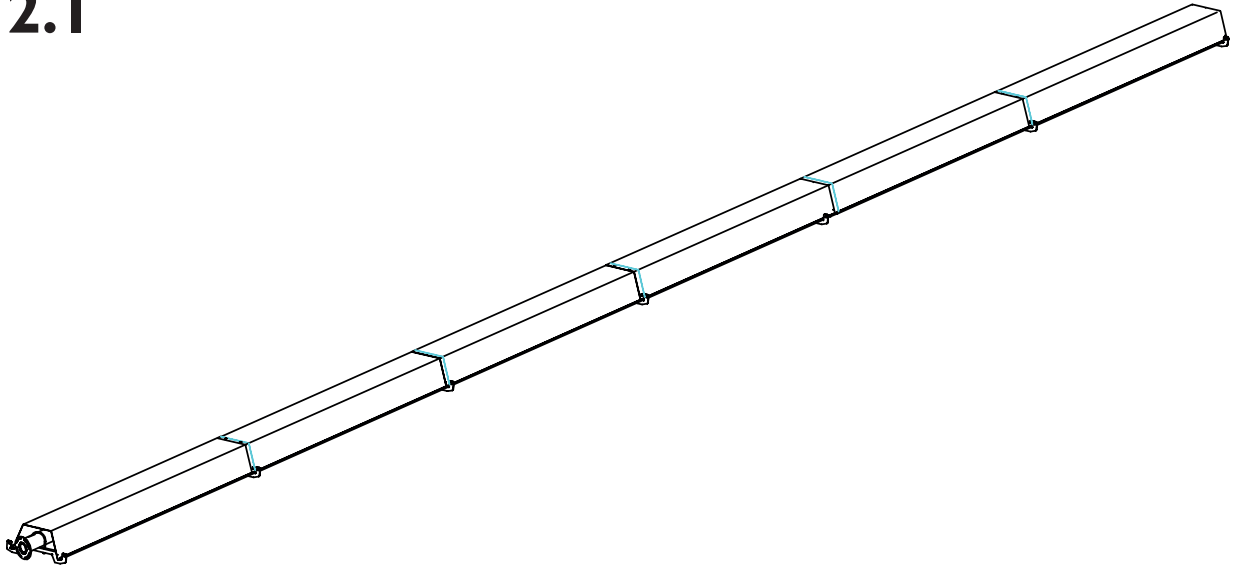

REFLECTOR PANEL
STRAHLUNGS KAPPE
RÉFLECTEUR
STRALINGKAP

6x

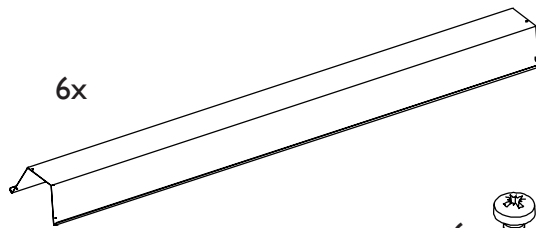

6x

6 Nm



M6x16

6x

2.2

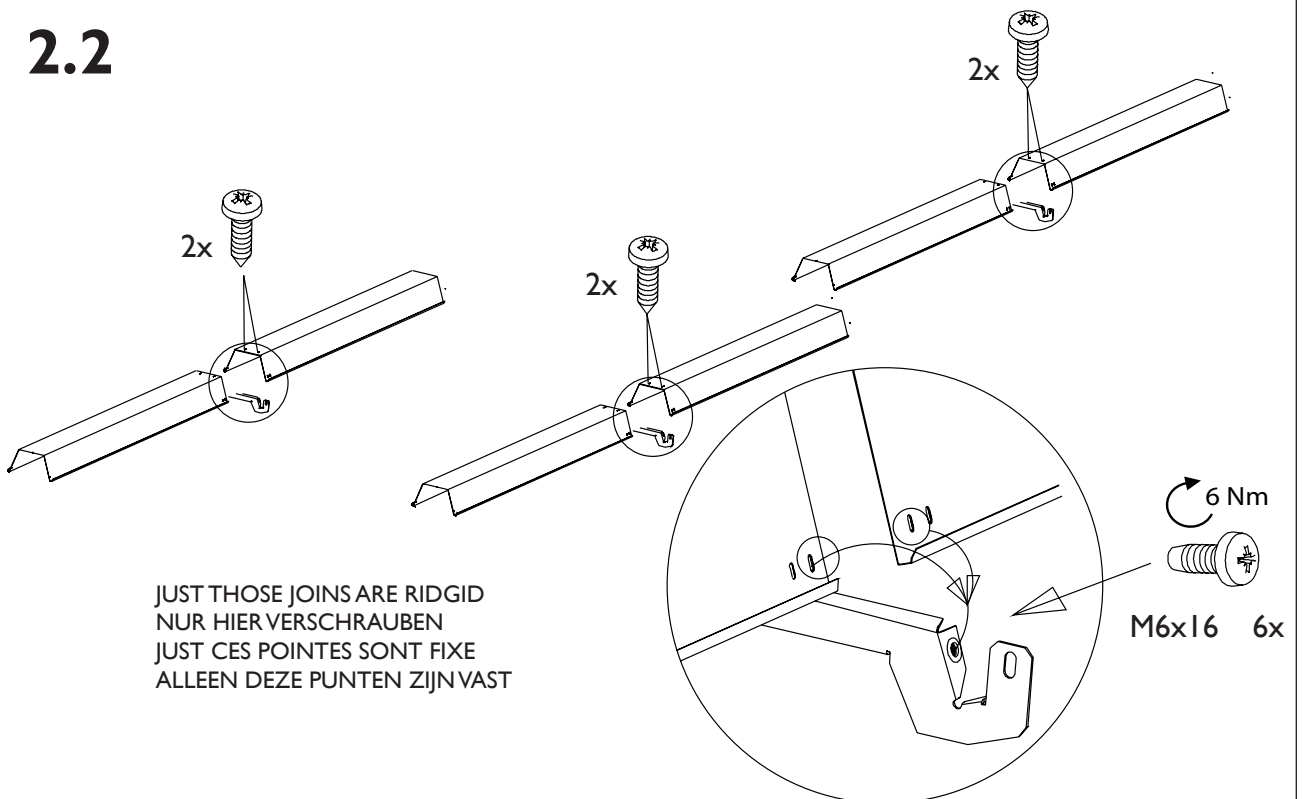

JUST THOSE JOINS ARE RIDGID
NUR HIER VERSCHRAUBEN
JUST CES POINTES SONT FIXE
ALLEEN DEZE PUNTEN ZIJN VAST

M6x16 6x

2.3

VERY IMPORTANT
SEHR WICHTIG
TRES IMPORTANT
HEEL BELANGRIJK

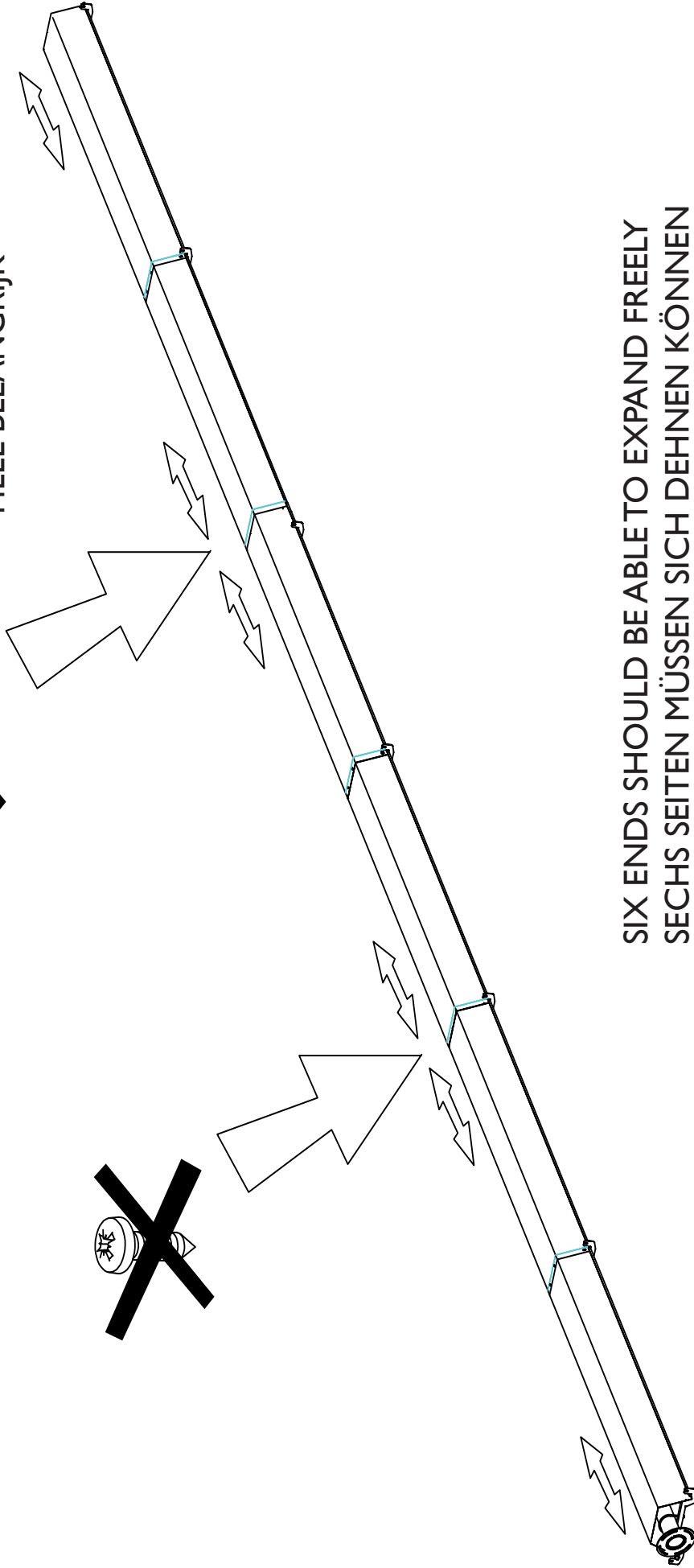
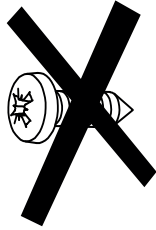
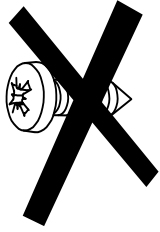

SIX ENDS SHOULD BE ABLE TO EXPAND FREELY
SECHS SEITEN MÜSSEN SICH DEHNEN KÖNNEN
LES SIX EXTRÊMITÈ DOIVENT ÊTRE EXTENSIBLE
ZES UITEINDEN MOETEN VRIJ KUNNEN UITZETTEN

2.4

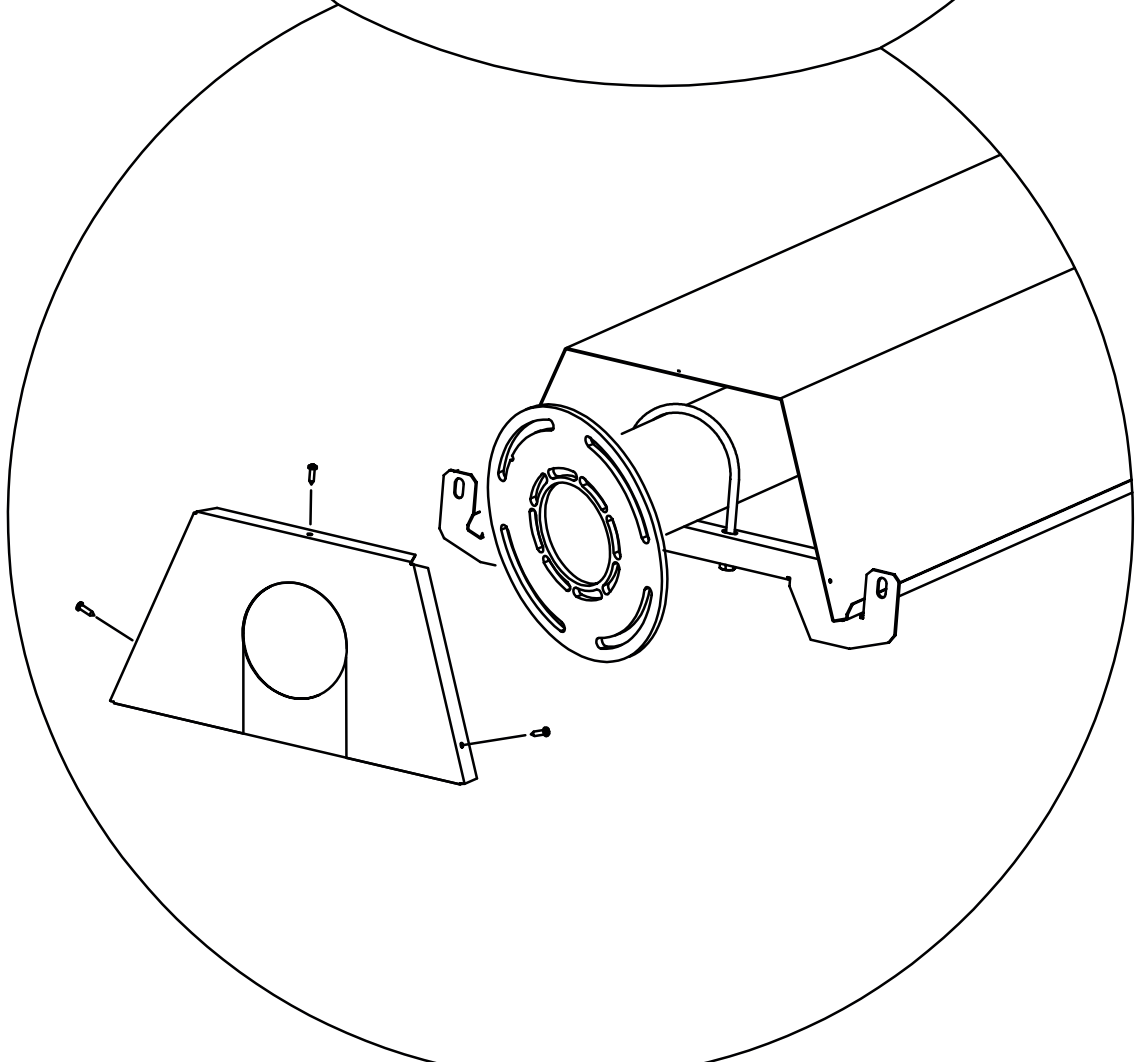
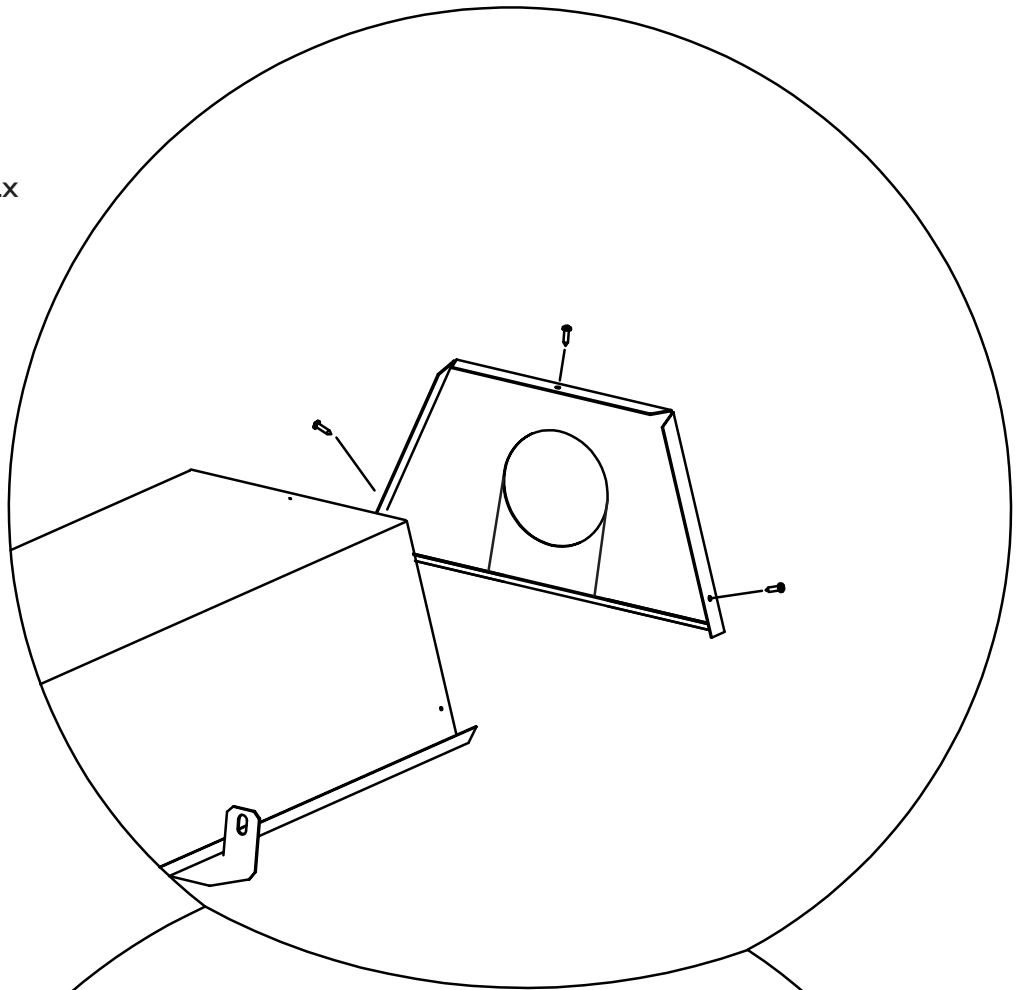
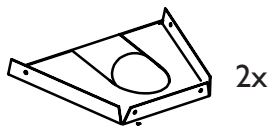

2.5

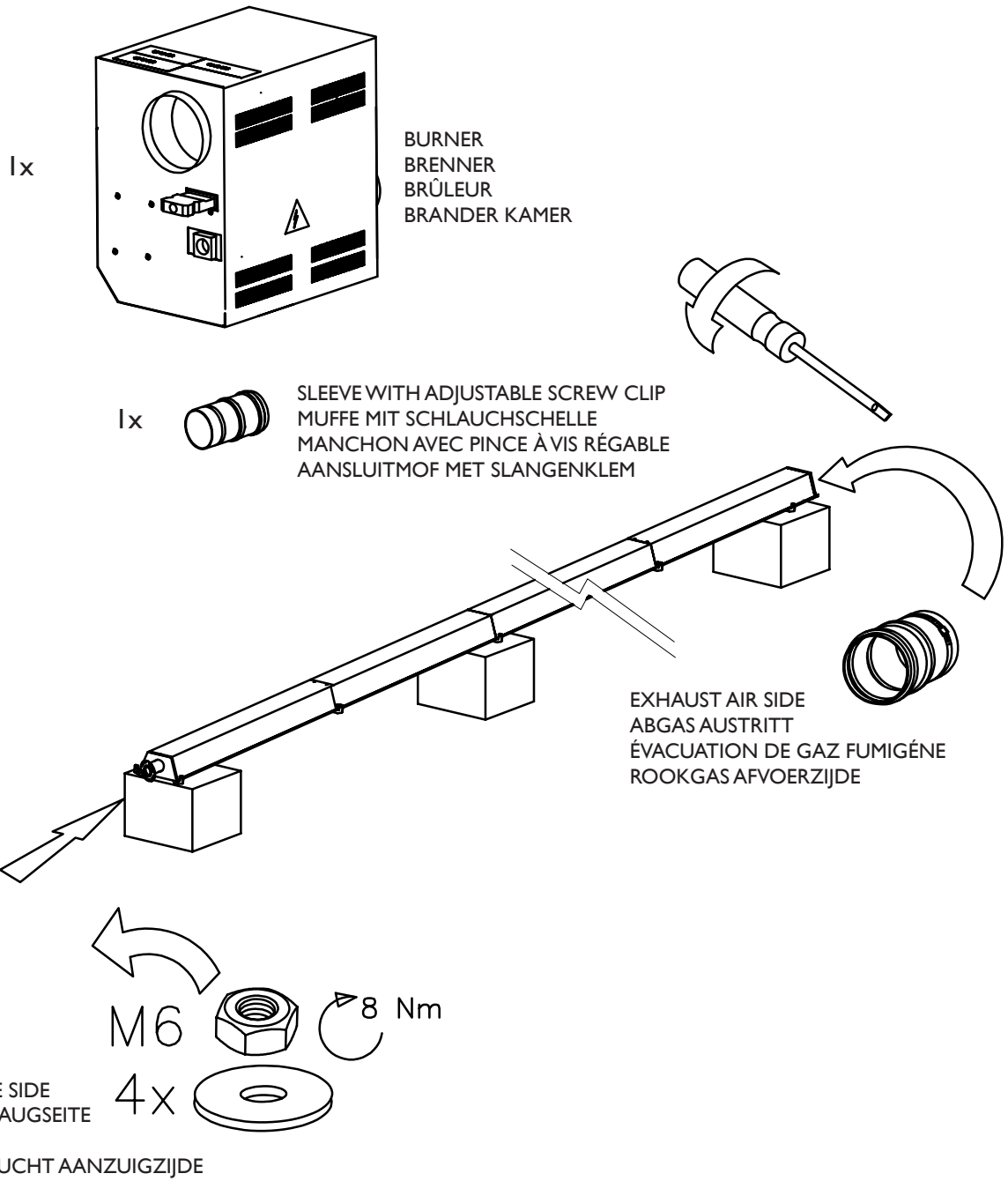

2.6

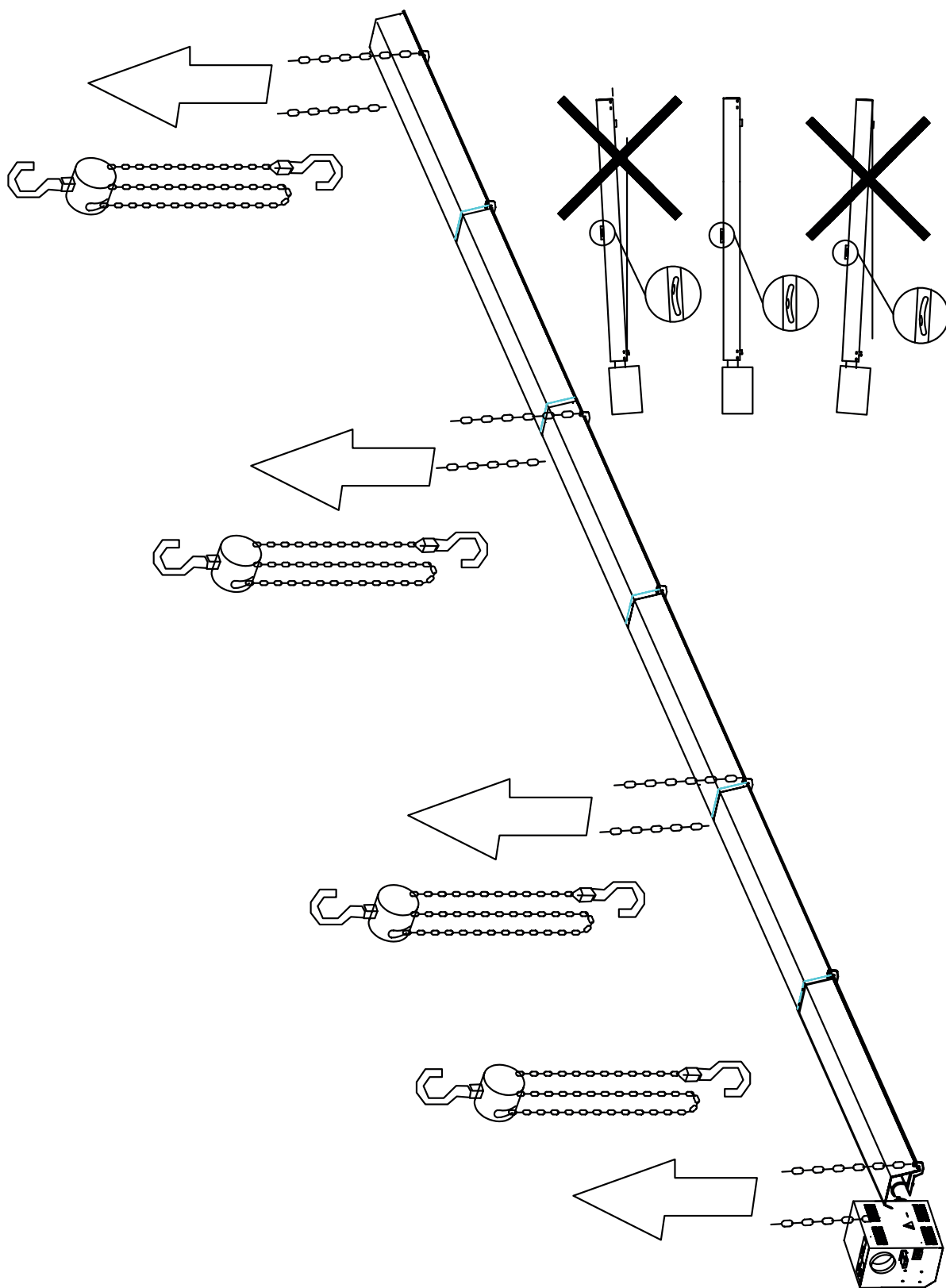

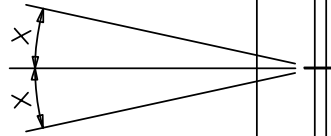
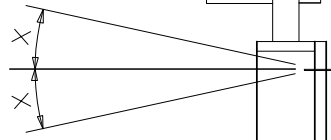
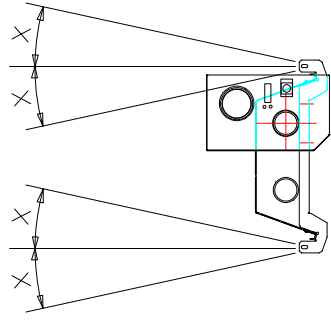
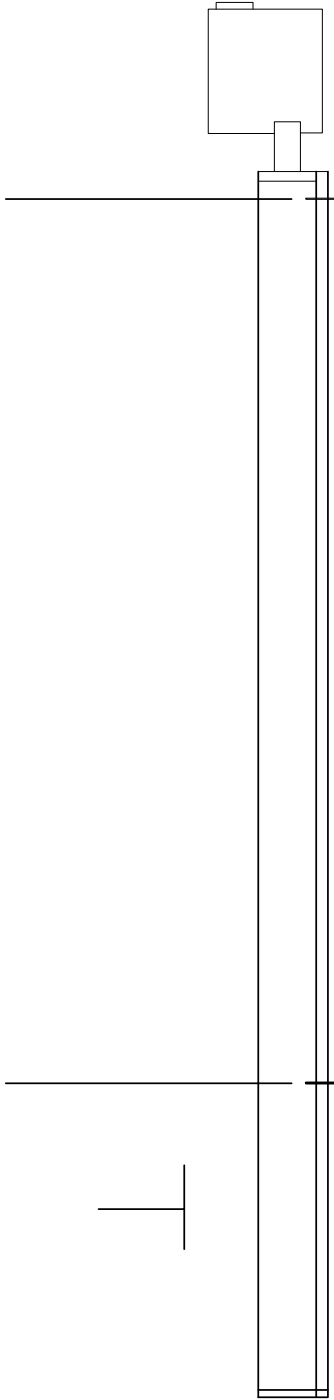
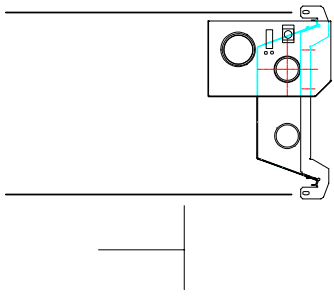

x = max. 15°

x = max. 15°

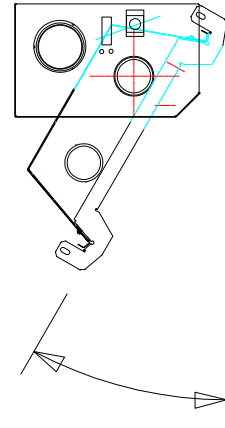

y = max.
30°

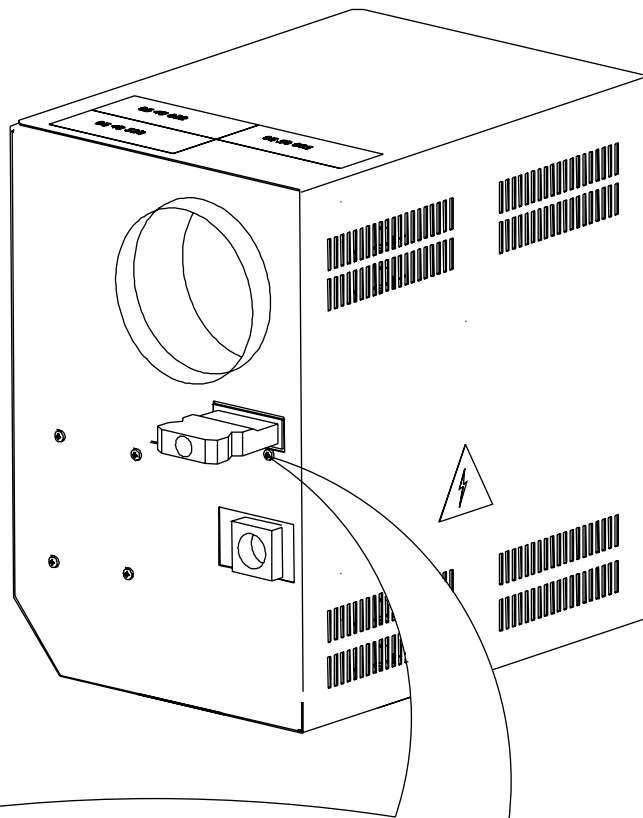

ON/OFF BURNER
AN/AUS BRENNER
MARCHE/ARRÊT BRÛLEUR
AAN/UIT BRANDER

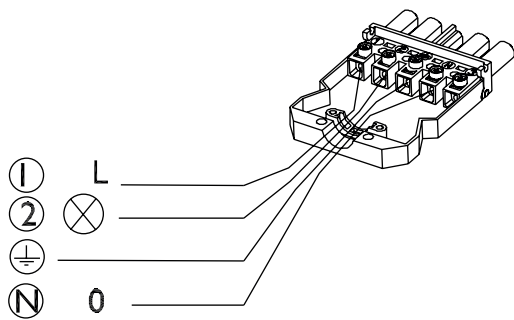

HIGH/LOW BURNER
STUFEN BRENNER
HAUTE/BAS BRÛLEUR
HOOG/LAAG BRANDER

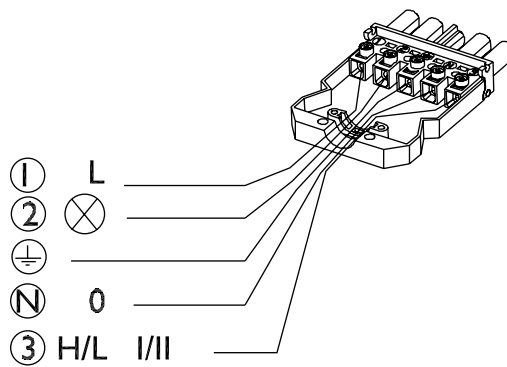

THERMO AIR BV
BENEDEN VERLAAT 87-89
9645 BM VEENDAM
TELEFOON +31(0)35 - 5249000

info@thermoair.nl
www.thermoair.nl

The logo for Thermo Air, featuring the word "THERMO" in red and "AIR" in blue, both in a bold, sans-serif font. The logo is positioned on a white rectangular background that is slightly offset from the bottom right corner of the page, creating a shadow effect.

**THERMO
AIR**