

THERMO
AIR

Montageanleitung **DE**

Mounting instruction **EN**

Notice de montage **FR**

Montagehandleiding **NL**

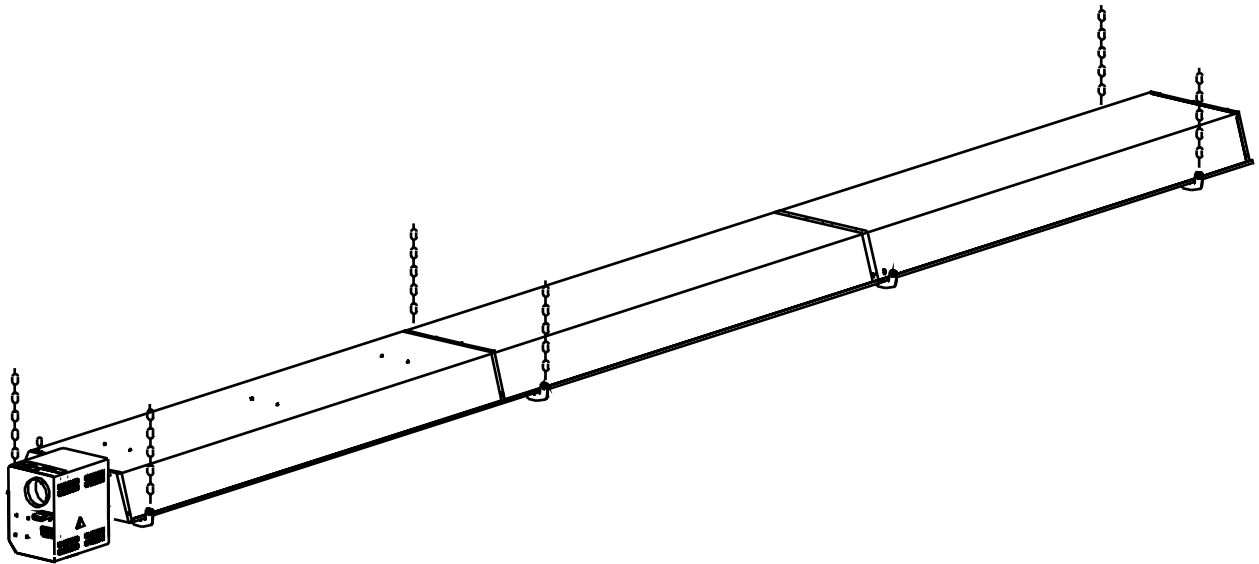





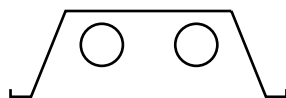

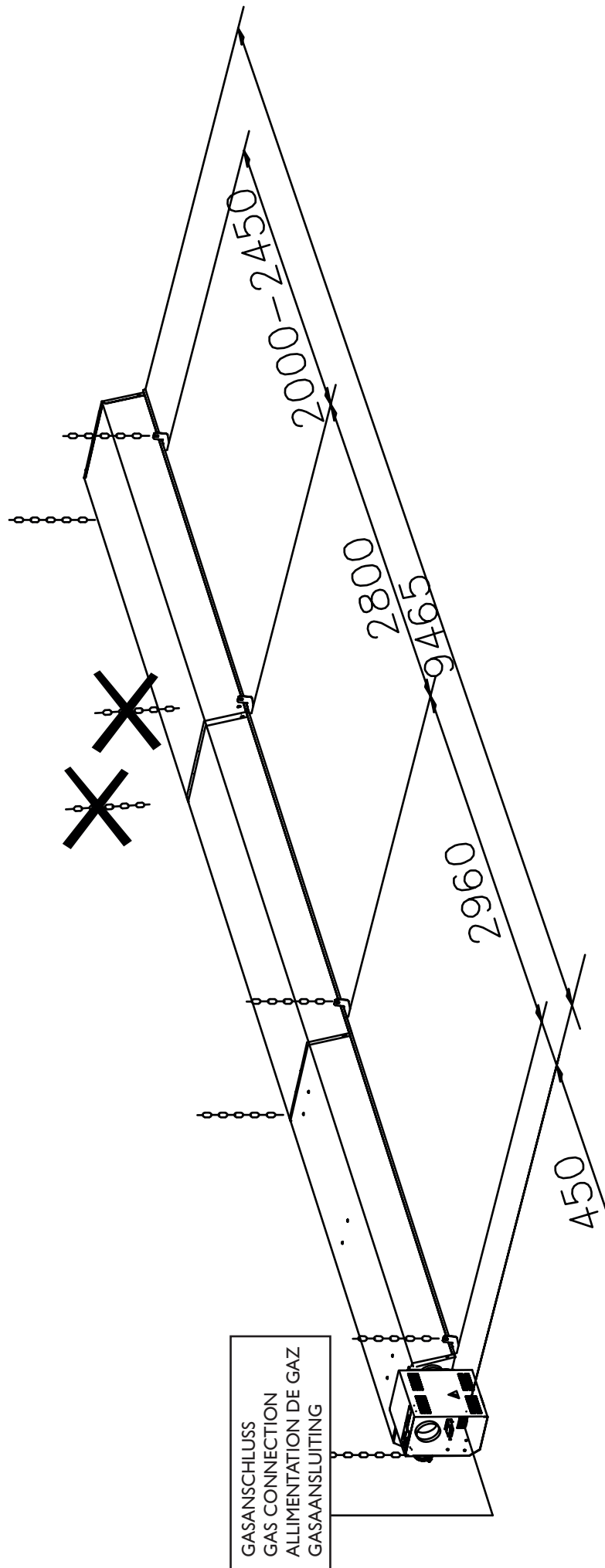

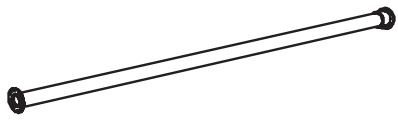
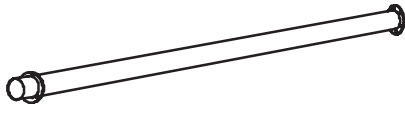
30-9
40-9
50-9

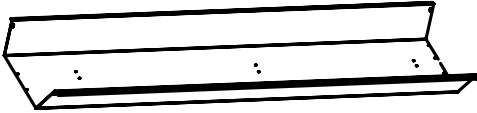
BH
0666554



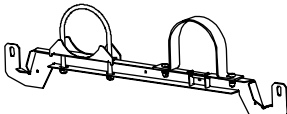
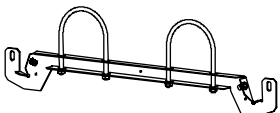
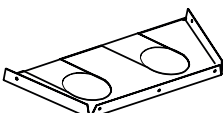
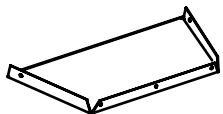
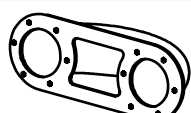
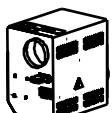

STRAHLUNGSROHR RADIANT TUBE TUBE RAYONNANT STRALINGSBUIS	L=2885	1x		30 61 373
STRAHLUNGSROHR RADIANT TUBE TUBE RAYONNANT STRALINGSBUIS	L=2885	1x		30 61 372
STRAHLUNGSROHR RADIANT TUBE TUBE RAYONNANT STRALINGSBUIS	L=2885	3x		30 61 371
STRAHLUNGSROHR RADIANT TUBE TUBE RAYONNANT STRALINGSBUIS	L=2885	1x		30 61 370
STRAHLUNGSKAPPE REFLECTOR PANEL RÉFLECTEUR STRALINGSKAP	L=2955	1x		14 55 110
TRIANGULAR REFLECTOR PANEL DREIECK STRAHLUNGSKAPPE RÉFLECTEUR TRIANGULAIRE STRALINGSKAP DRIEHOEK	L=2955	1x		14 55 124
STRAHLUNGSKAPPE REFLECTOR PANEL RÉFLECTEUR STRALINGSKAP	L=2955	2x		14 55 112
TURBULATOR RETARDER RETARDEUR RETARDER	L=1500	1x	 TURBULATOR IST SCHON IM ROHR MONTIERT RETARDER IS ALREADY MOUNTED IN TUBE RETARDEUR EST MONTEZ DANS LA TUBE RETARDER IS AL IN DE BUIS GEPLAATST	11 11 195
MONTAGEBÜGEL SUSPENSION BRACKET ETRIER DE SUSPENSION OPHANGBEUGEL		2x		30 87 330
MONTAGEBÜGEL SUSPENSION BRACKET ETRIER DE SUSPENSION OPHANGBEUGEL		2x		30 87 332
ENDKAPPE END PLATE PLAQUES D'EXTRÉMITÉ STRALINGSEINDKAP		1x		30 87 335
ENDKAPPE END PLATE PLAQUES D'EXTRÉMITÉ STRALINGSEINDKAP		1x		14 55 019
UMKEHRBOGEN BEND 180° COUDE 180° OMKEERBOCHT		1x		30 61 381
BRENNER BURNER BRÛLEUR BRANDERKAMER		1x		
MUFFE MIT SCHLAUCHSCHELLE SLEEVE WITH ADJUSTABLE SCREW CLIP MANCHON AVEC PINCE À VIS RÉGABLE AANSLUITMOF		1x		30-9: 30 19 029 40-9: 30 19 033 50-9: 30 19 033

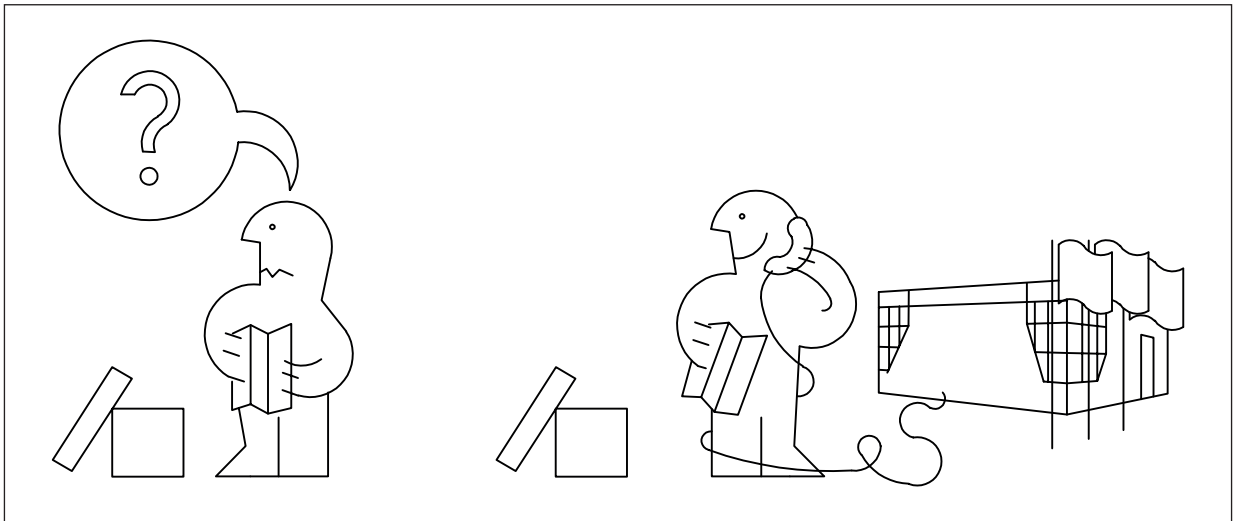
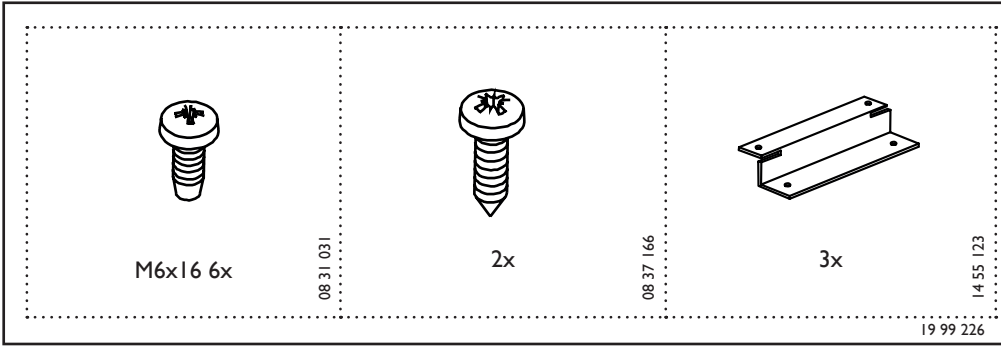
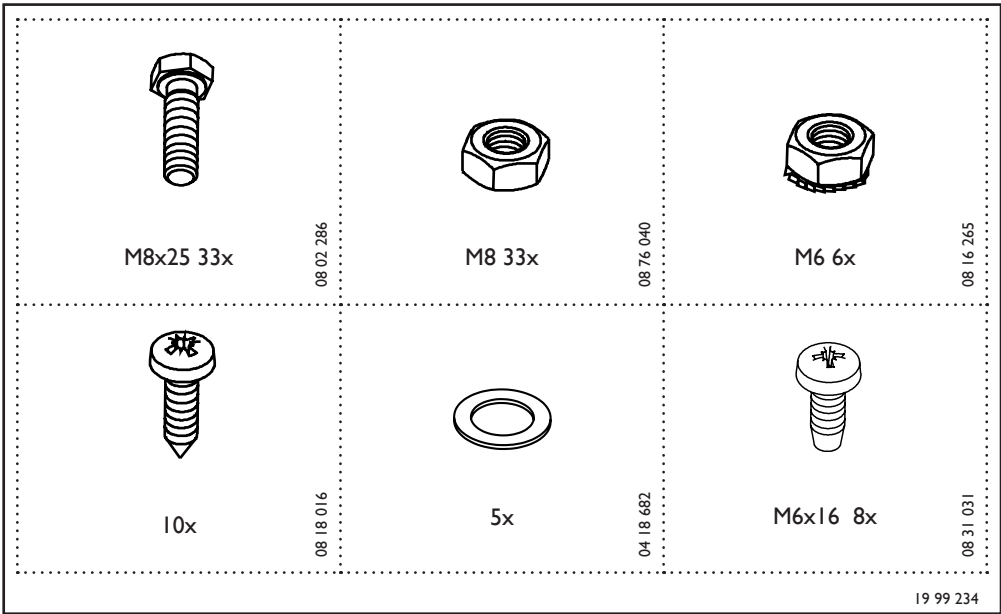

1.1

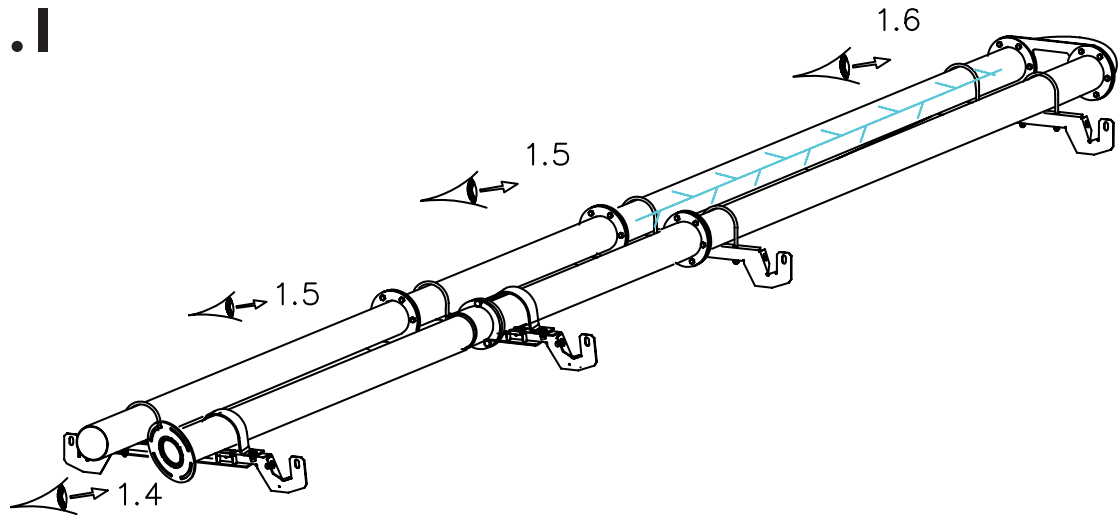

1.2

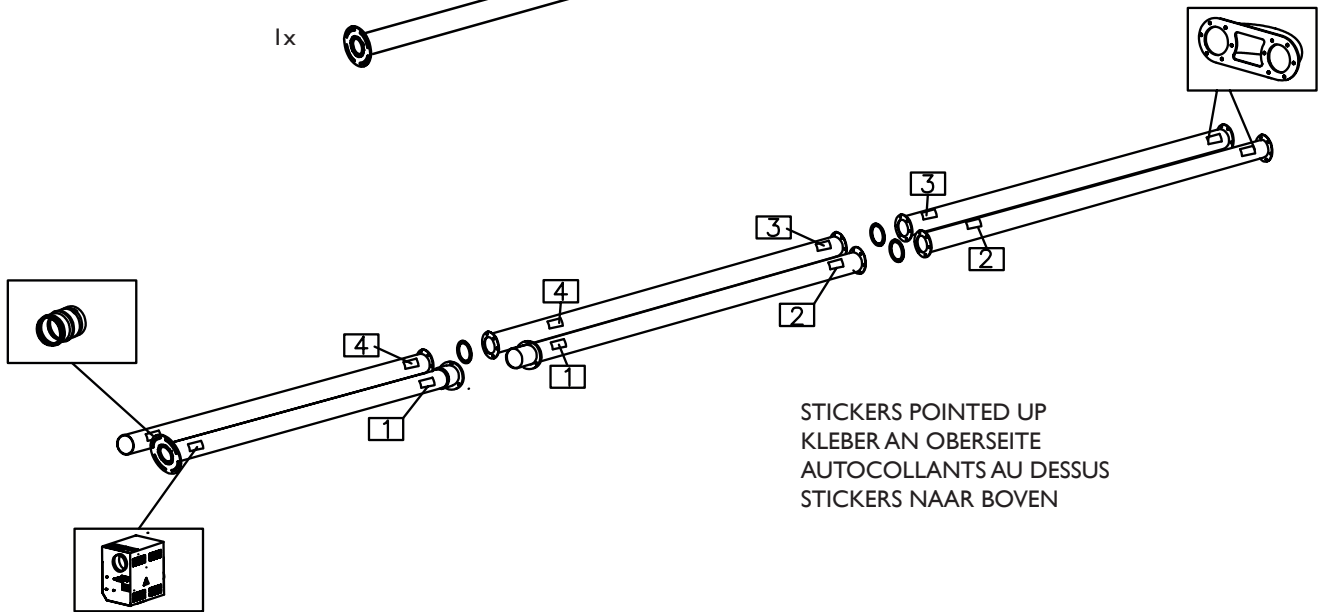
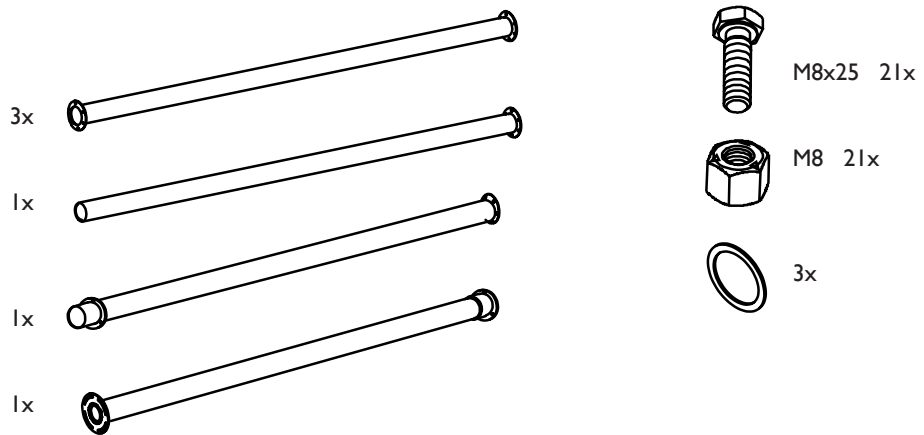

I.3

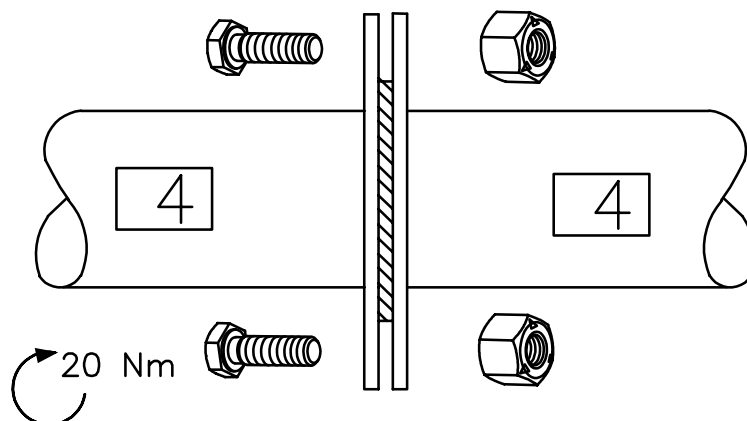
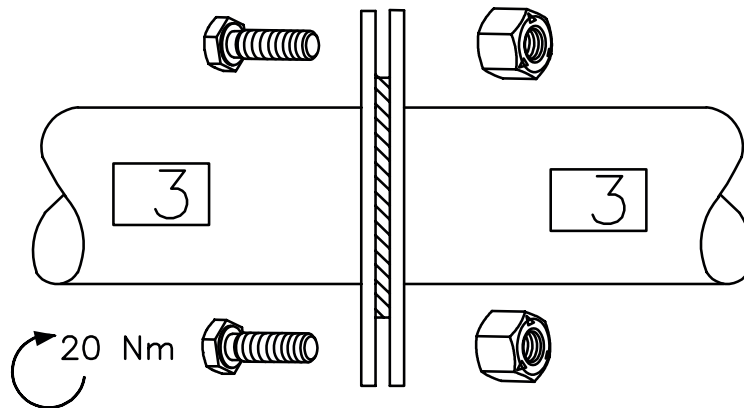
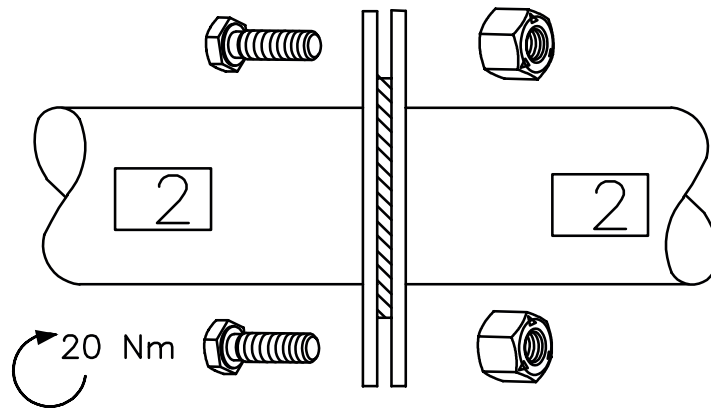
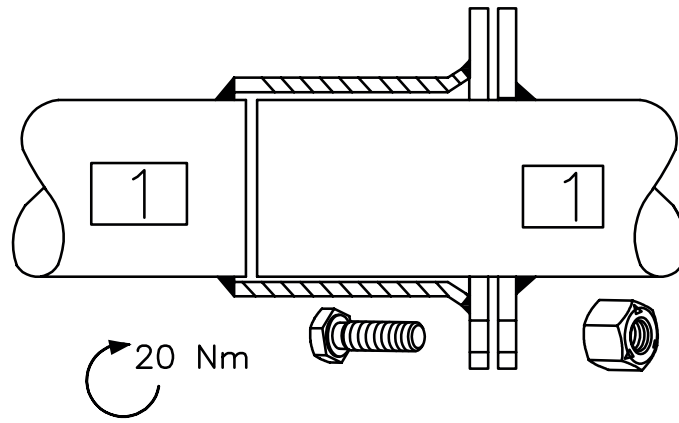

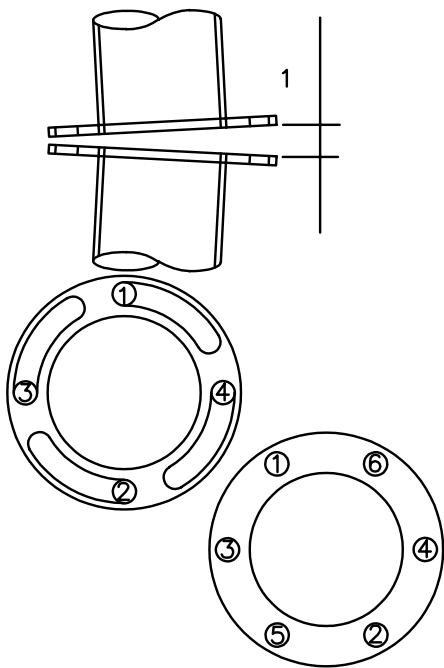

BOLT UP THE WIDEST GAP FIRST
 DIE BREITESTE ÖFFNUNG ZUERST VERSCHRAUBEN
 BOULONNER LE PLUS LARGE PREMIER
 DE BOUT DIE BIJ DE GROOTSTE FLENSOPENING ZIT EERST

STEP 1: 30%, STEP 2: 60%, STEP 3: 100%, FINAL PULL: 100%
 SCHRITT 1: 30%, SCHRITT 2: 60%, SCHRITT 3: 100%, NACHZIEHEN: 100%
 ÉTAPPE 1: 30%, ÉTAPPE 2: 60%, ÉTAPPE 3: 100%, TIRAGE FINAL: 100%
 STAP 1: 30%, STAP 2: 60%, STAP 3: 100%, AFCIRKELEN: 100%

1.4

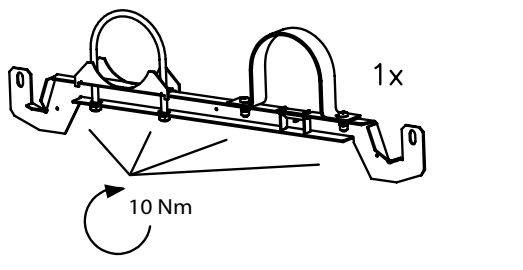

! VERY IMPORTANT
 SEHR WICHTIG
 TRES IMPORTANT
 ● HEEL BELANGRIJK

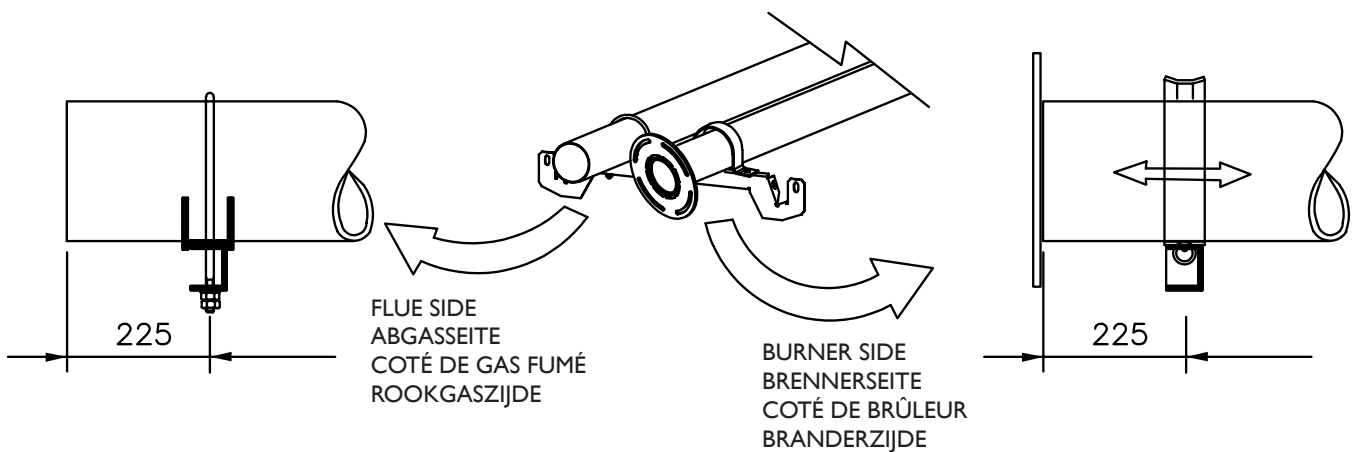

1.5

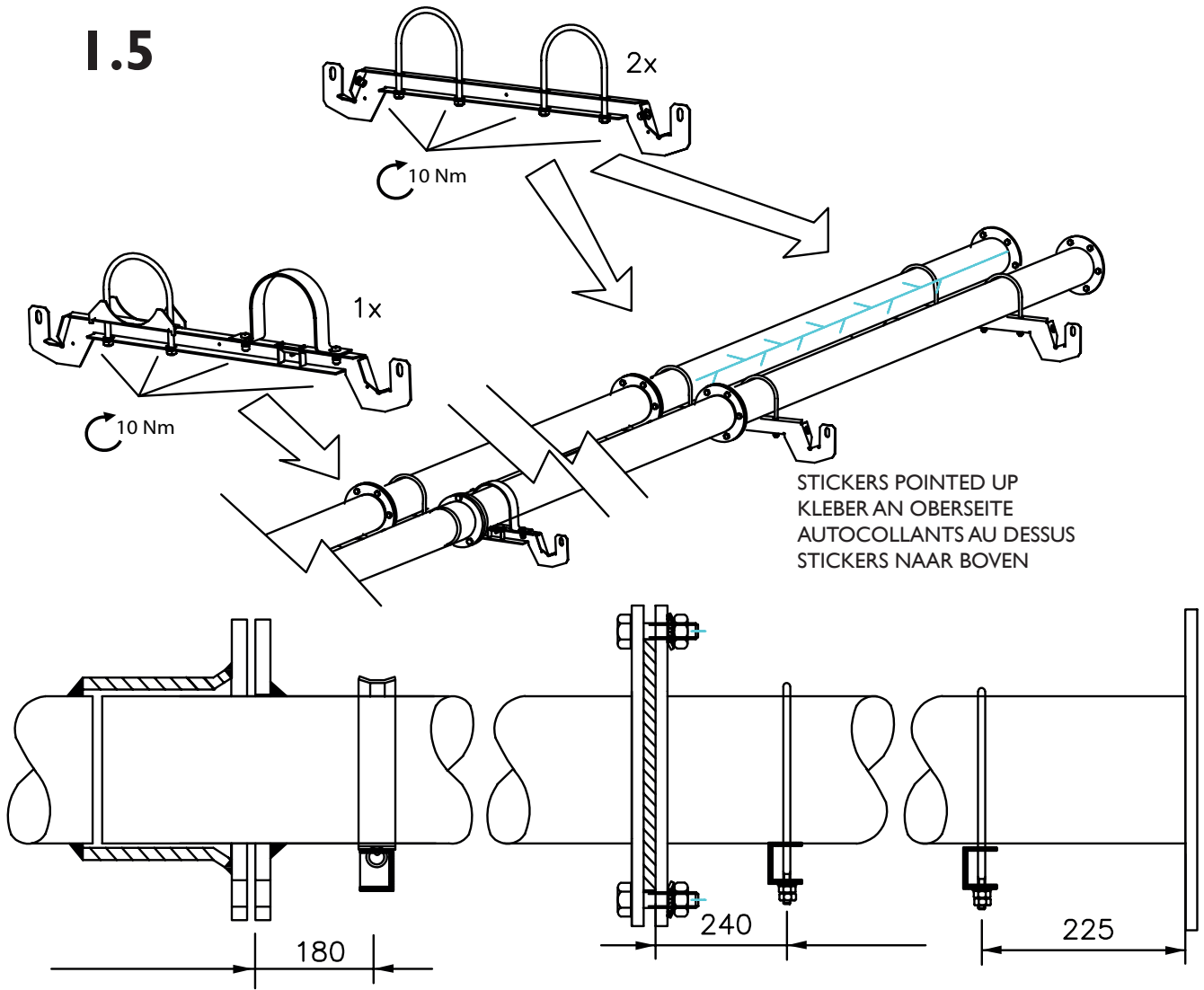

1.6

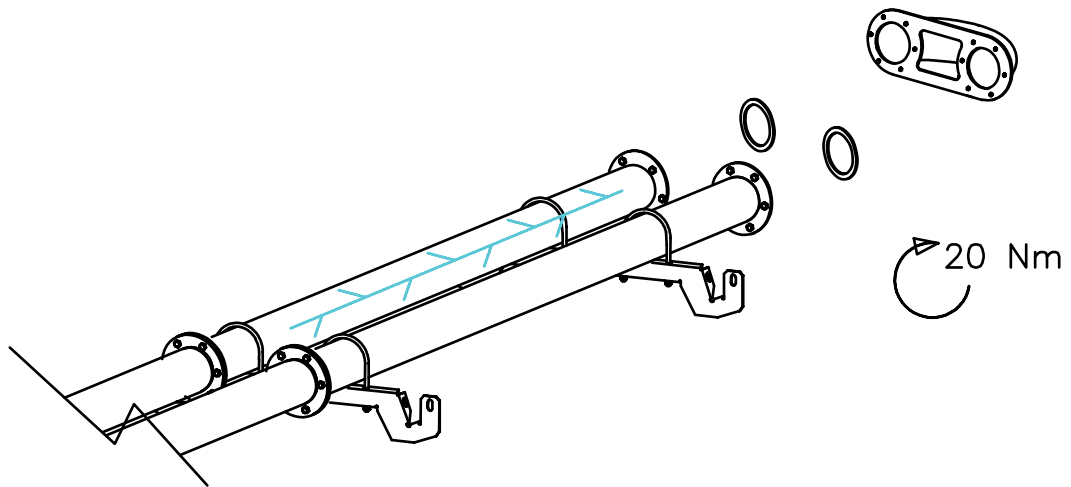
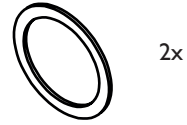
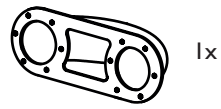

1.1...1.6

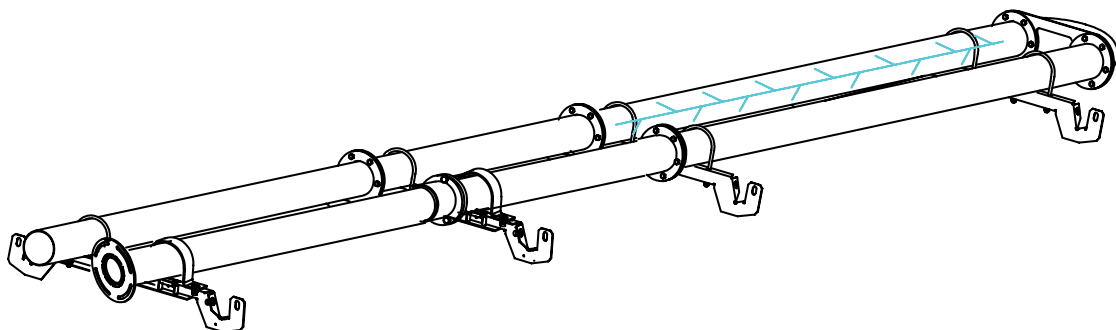

2.1

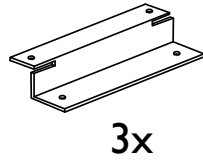
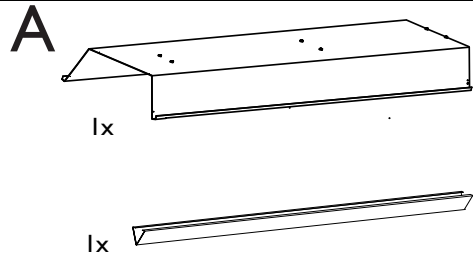
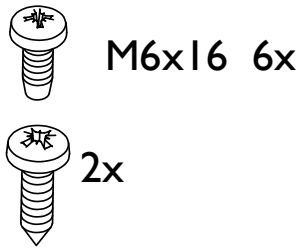

2.1.1

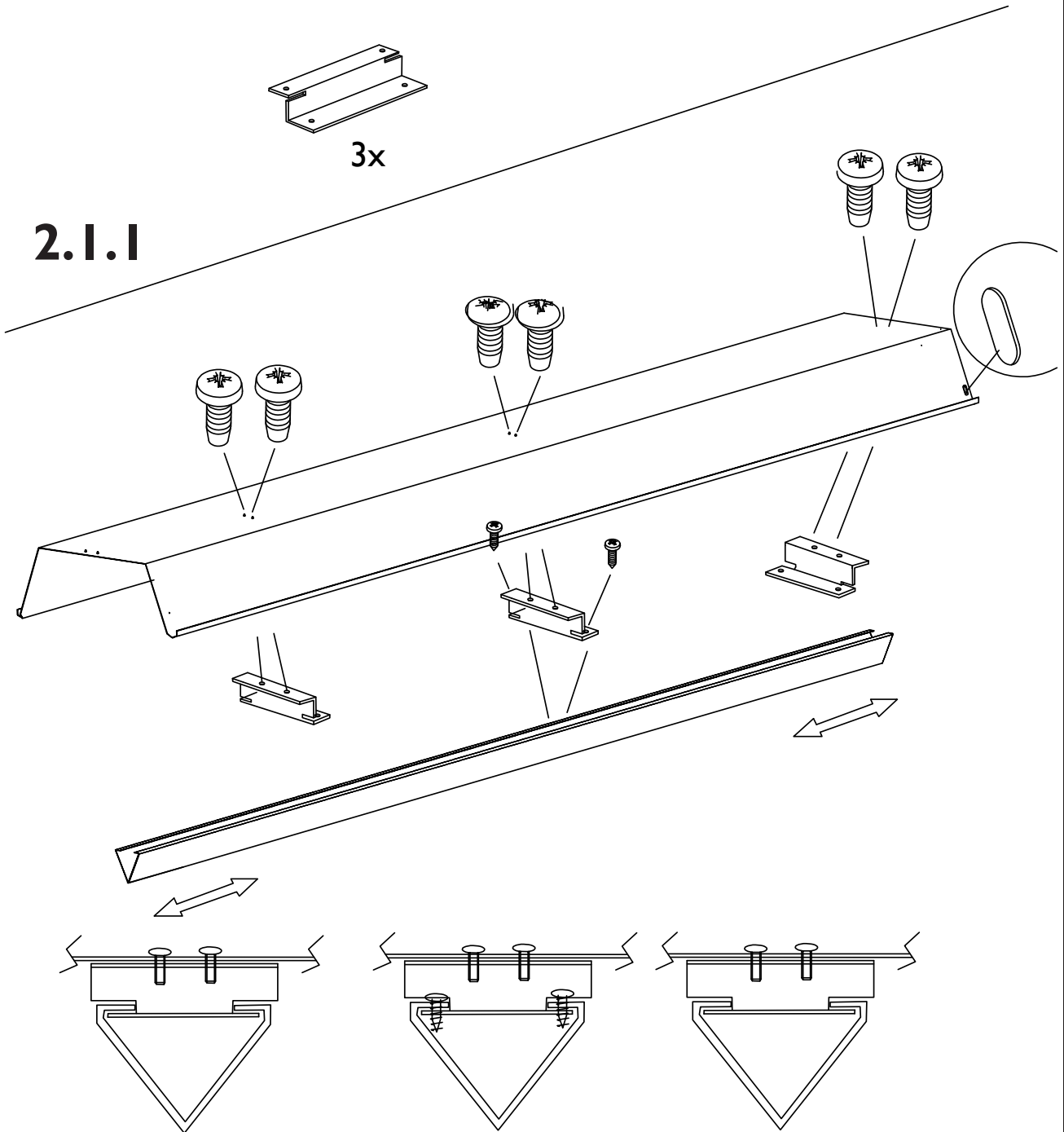

2.2.2

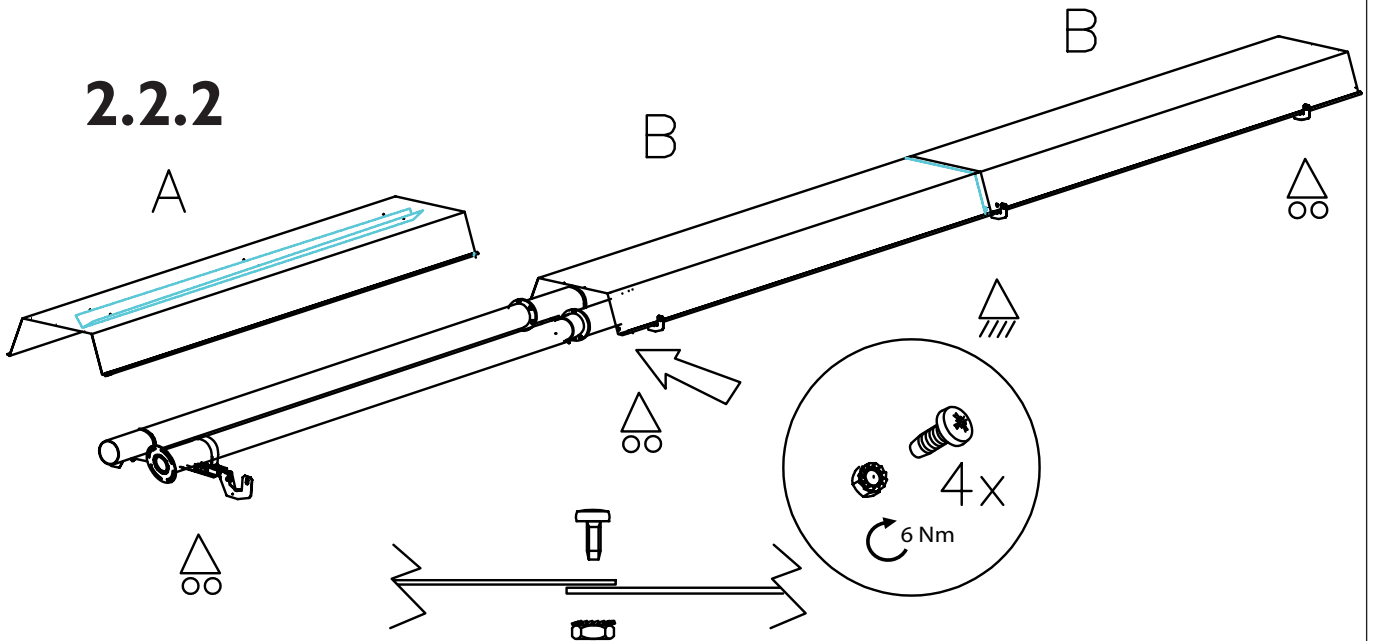

2.3

END PLATE
ENDKAPPE
PLAQUES D'EXTRÉMITÉ
STRALINGSEINDKAP

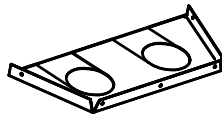

10x

1x

END PLATE
ENDKAPPE
PLAQUES D'EXTRÉMITÉ
STRALINGSEINDKAP

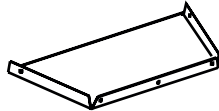

1x

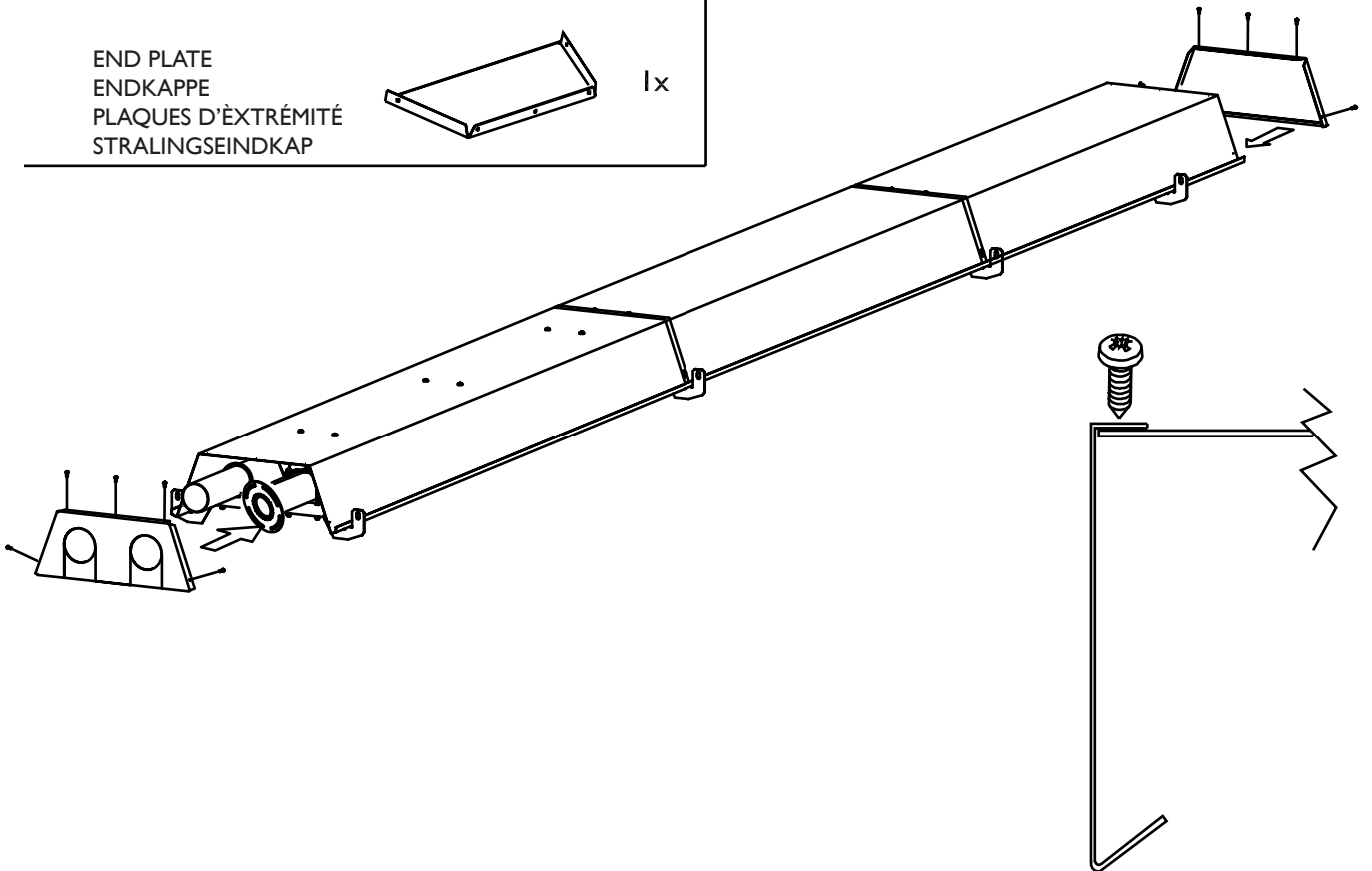

3.1

BURNER
BRENNER
BRÛLEUR
BRANDERKAMER

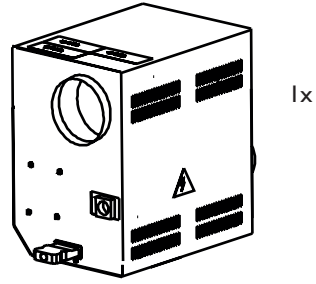

SLEEVE WITH ADJUSTABLE SCREW CLIP
MUFFE MIT SCHLAUSCHSELLE
MANCHON AVEC PINCE À VIS RÉGABLE
AANSLUITMOF MET SLANGENKLEM

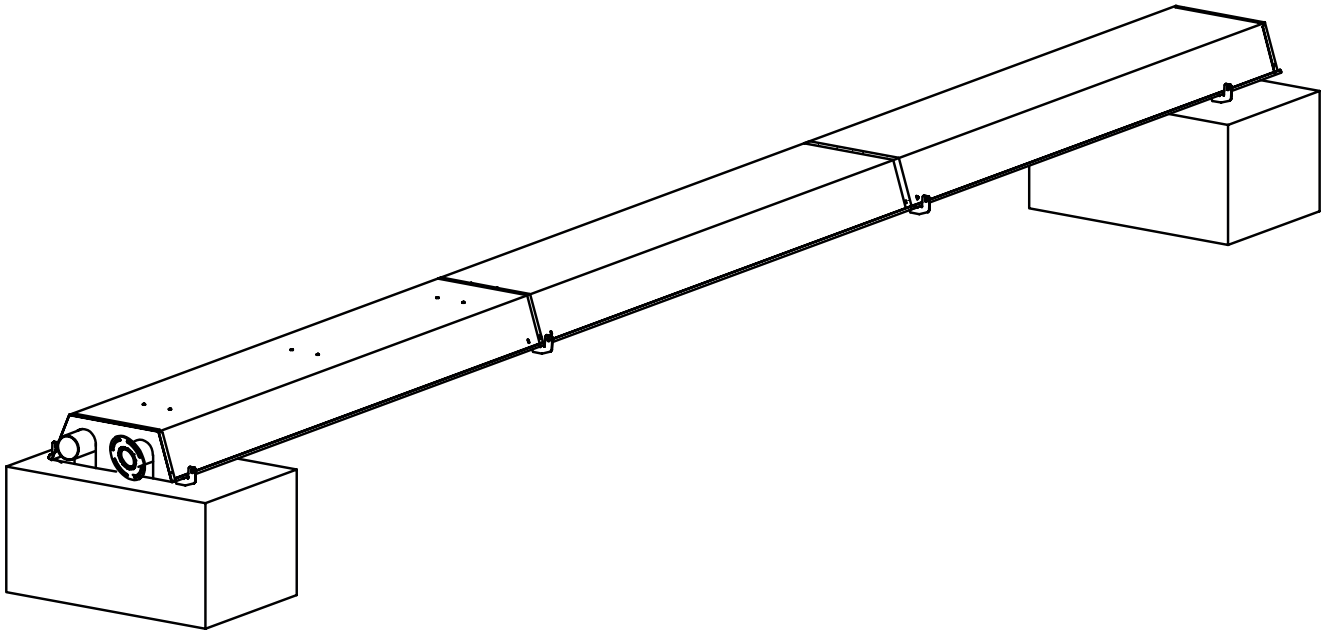

EXHAUST AIR SIDE
ABGAS AUSTRITT
ÉVACUATION DE GAZ FUMIGÈNE
ROOKGAS AFVOERZIJDE

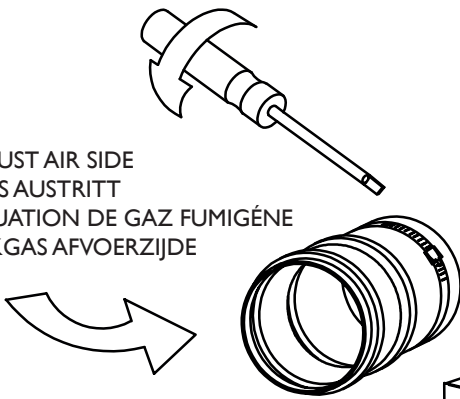

FRESH AIR INTAKE SIDE
FRISCH LUFT ANSAUGSEITE
ARRIVÉE D'AIR
VERBRANDINGSLUCHT AANZUIGZIJDE

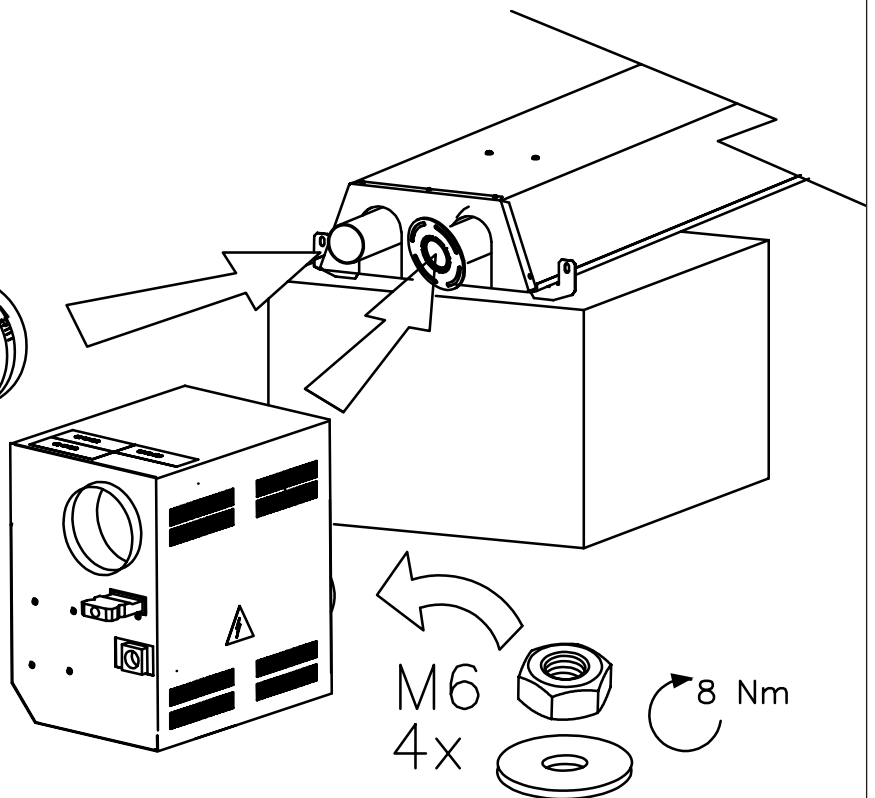

3.2

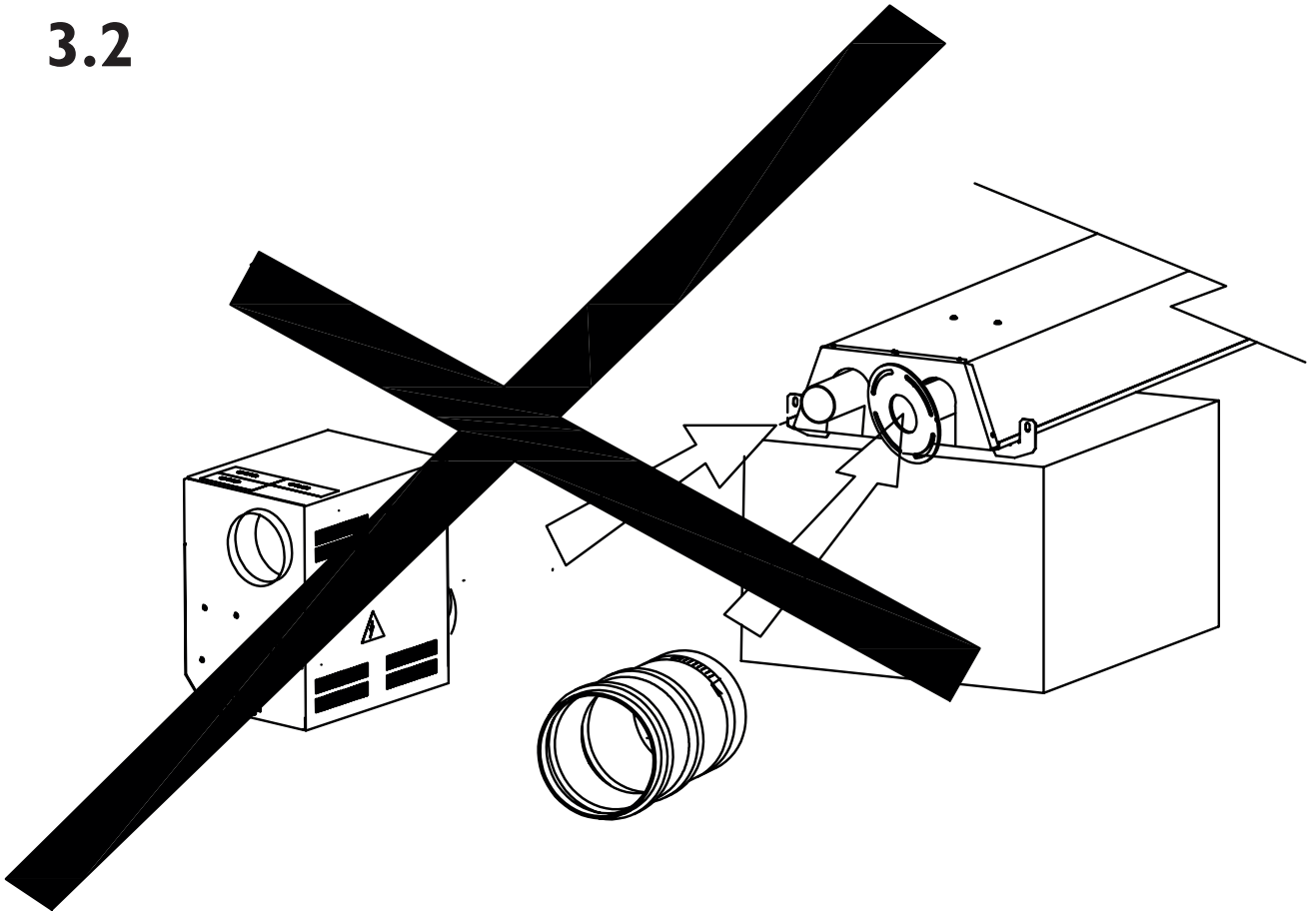

3.3

y = max.
30°

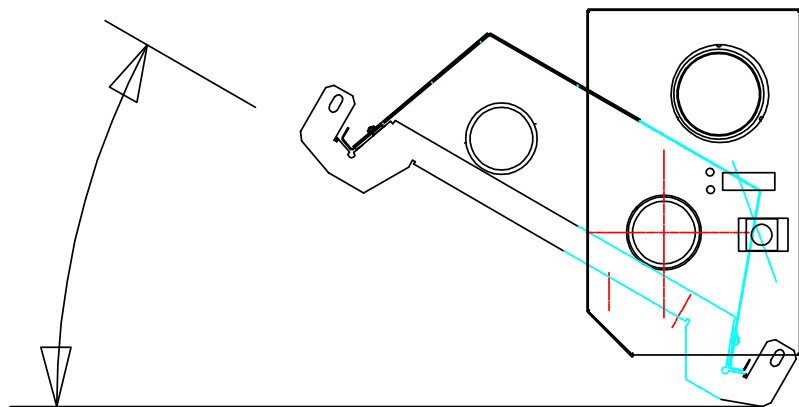

3.4

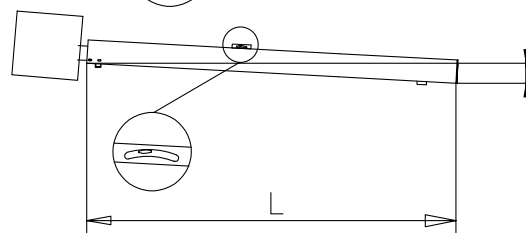
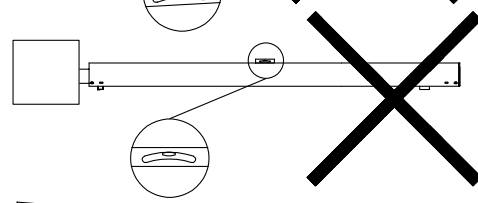
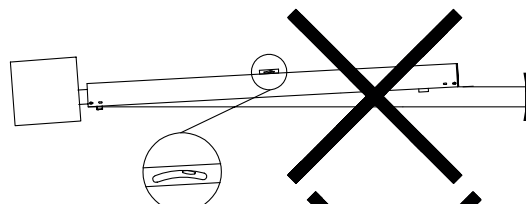
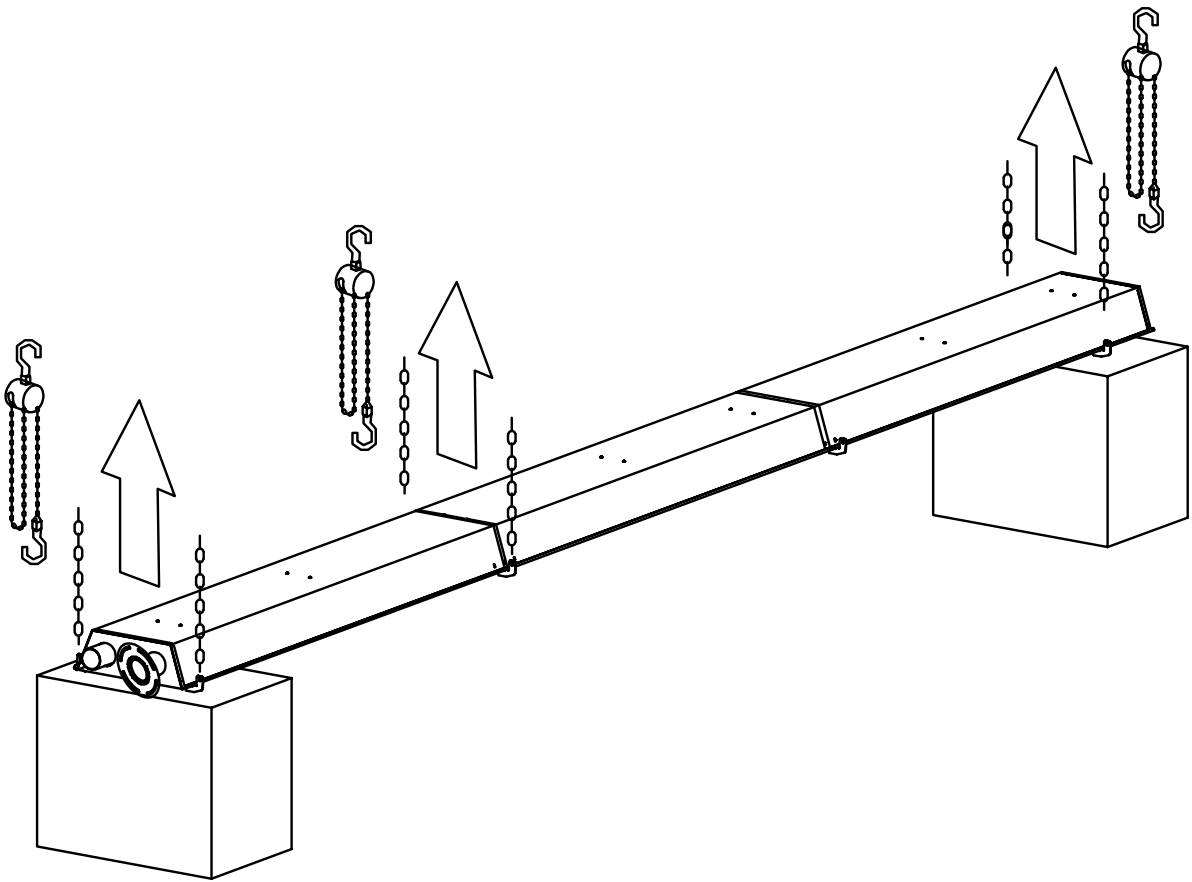

$$\frac{x}{L} = \frac{1}{100}$$

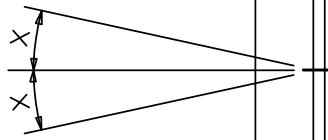
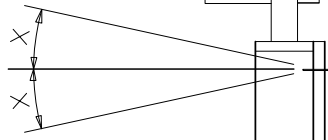
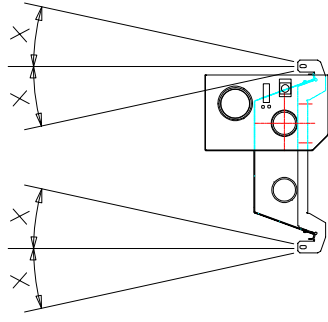
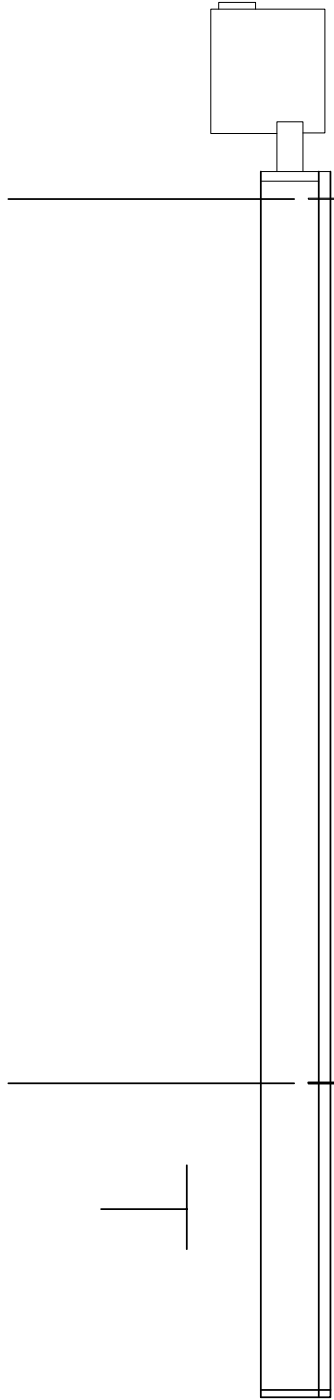
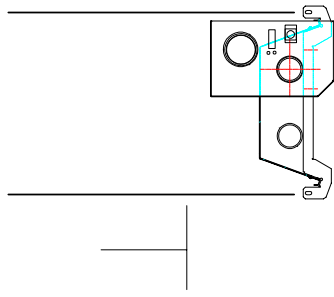

x = max. 15°

x = max. 15°

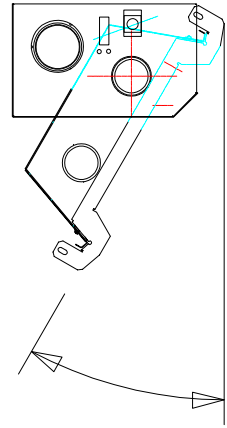

y = max.
30°

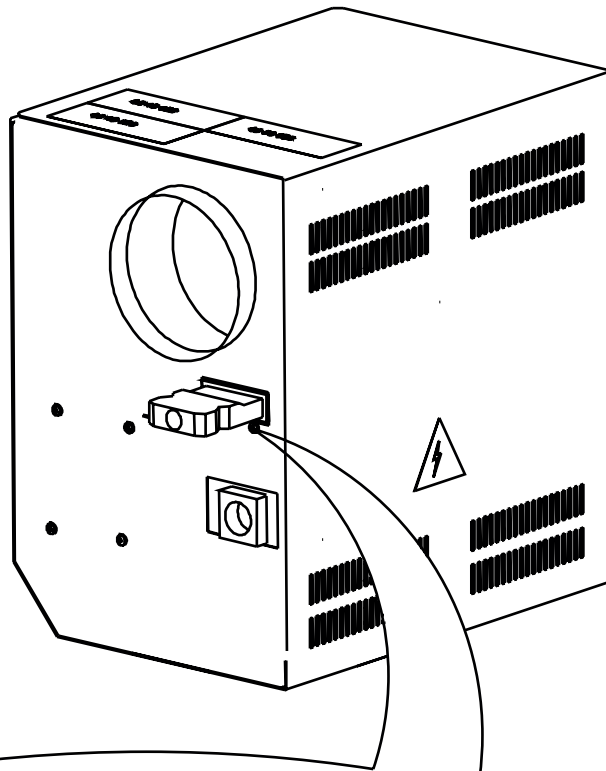

ON/OFF BURNER
 AN/AUS BRENNER
 MARCHÉ/ARRÊT BRÛLEUR
 AAN/UIT BRANDER

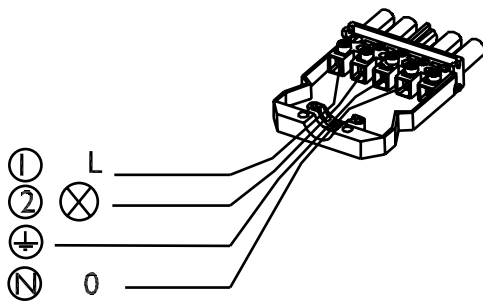

HIGH/LOW BURNER
 2 STUFEN BRENNER
 HAUTE/BAS BRÛLEUR
 HOOG/LAAG BRANDER

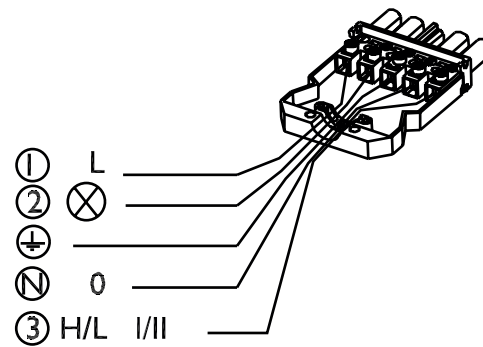

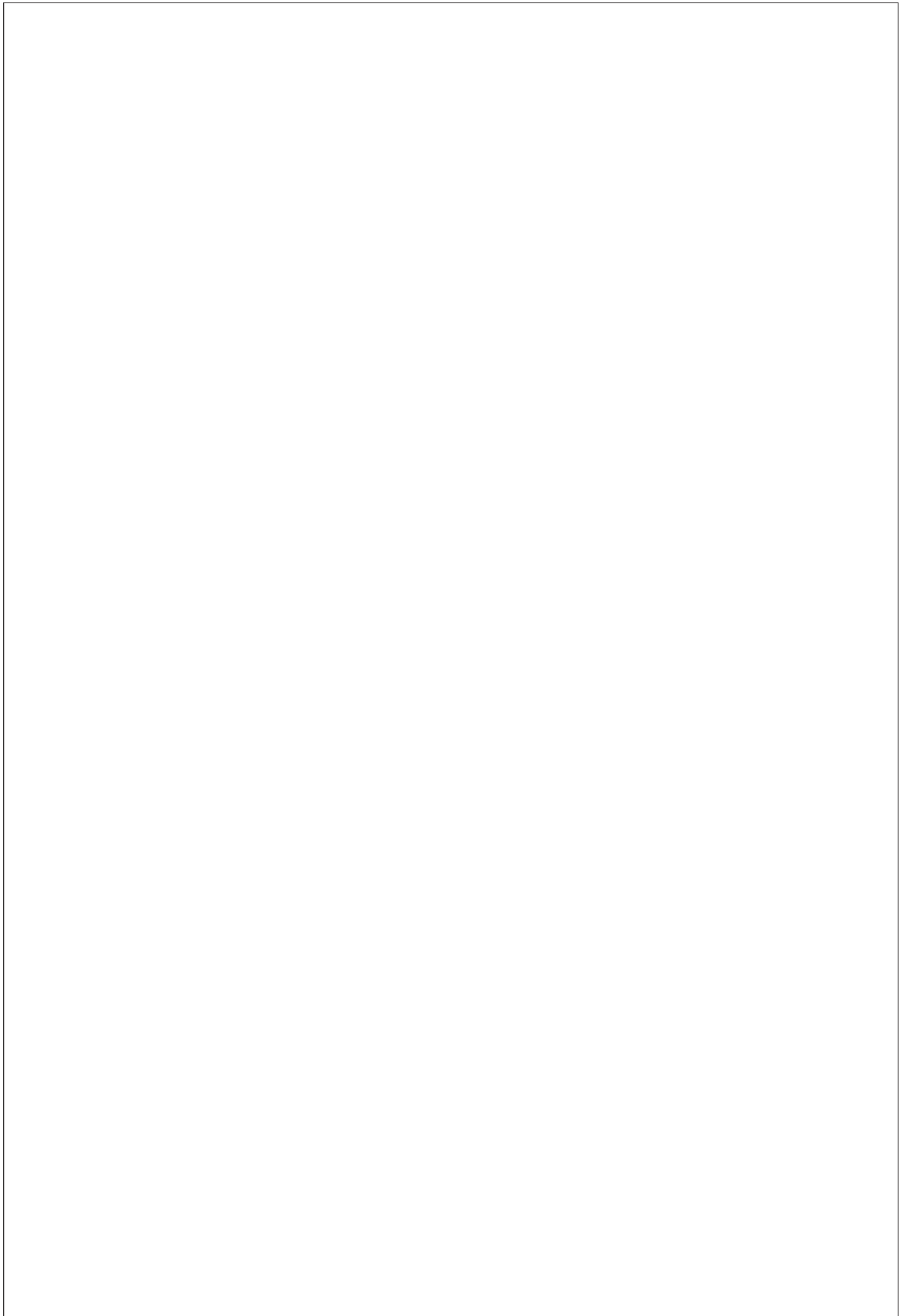

THERMO AIR BV
BENEDEN VERLAAT 87-89
9645 BM VEENDAM
TELEFOON +31(0)35 - 5249000

info@thermoair.nl
www.thermoair.nl

The logo for Thermo Air, featuring the word "THERMO" in red and "AIR" in blue, both in a bold, sans-serif font, set against a white background with a slight shadow.

THERMO
AIR